

Operating manual

ARR 1575
Yanmar

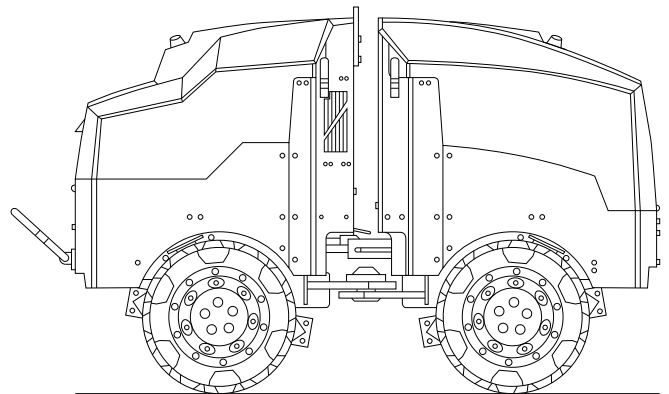

ARR 1575
Trench roller
Yanmar Tier 4 final

Operating manual

Edition 02/2018 EN

From Serial No. 5572000

Translation of Original Operating Manual

ES / EU Prohlášení o shodě

(Původní ES/EU prohlášení o shodě / Original EC/EU Declaration of conformity / Ursprüngliche EG-/EU-Konformitätserklärung)

EC / EU Declaration of conformity / EG-/EU-Konformitätserklärung

(Překlad původního ES/EU prohlášení o shodě / Translation original EC/EU Declaration of conformity / Übersetzung der ursprünglichen EG-/EU-Konformitätserklärung)

Originální ES/EU prohlášení o shodě je dodané s dokumenty během expedice stroje. / The original EC/EU Declaration of Conformity is supplied with documents during expedition of machine. / Das Original der EG-/EU-Konformitätserklärung wird mit den Unterlagen während des Versands der Maschine mitgeliefert.

Výrobce / Manufacturer / Hersteller:	Ammann Czech Republic a.s.
Adresa / Address / Adresse:	Náchodská 145, CZ-549 01 Nové Město nad Metují, Czech Republic
IČ / Identification Number / Ident.-Nr.:	000 08 753
Jméno a adresa osoby pověřené sestavením technické dokumentace podle 2006/42/ES a jméno a adresa osoby, která uchovává technickou dokumentaci podle 2000/14/ES / Name and address of the person authorised to compile the technical file according to 2006/42/EC and name and address of the person, who keeps the technical documentation according to 2000/14/EC / Name und Adresse der mit der Zusammenstellung der technischen Dokumentation beauftragten Person gemäß 2006/42/EG und Name und Adresse der mit der Aufbewahrung der technischen Dokumentation beauftragten Person gemäß 2000/14/EG:	Ing. Radek Ostrý Ammann Czech Republic a.s. Náchodská 145, CZ-549 01 Nové Město nad Metují, Czech Republic
Popis strojního zařízení / Description of the machinery / Beschreibung der Maschineneinrichtung:	
Označení / Designation / Bezeichnung:	Příkopový válec / Trench Roller / Grabenwalze
Typ / Type / Typ:	ARR 1575
Verze / Version / Version:	
Výrobní číslo / Serial number / Maschinenummer:	
Motor / Engine / Motor:	YANMAR 3TNV80F-SPAMM, vznětový, jmenovitý výkon (ISO 3046-1): 14,6 kW, jmenovité otáčky: 2400 min ⁻¹ . / YANMAR 3TNV80F-SPAMM, Diesel, nominal power (ISO 3046-1): 14,6 kW, rated speed: 2400 RPM. / YANMAR 3TNV80F-SPAMM, Nennleistung (ISO 3046-1): 14,6 kW, Nenndrehzahl: 2400 min ⁻¹ .
Prohlašujeme, že strojní zařízení splňuje všechna příslušná ustanovení uvedených směrnic / We declare, that the machinery fulfils all the relevant provisions mentioned Directives / Wir erklären, dass die Maschineneinrichtung sämtliche entsprechenden Bestimmungen aufgeführter Richtlinien erfüllt:	Strojní zařízení – směrnice 2006/42/ES / Machinery Directive 2006/42/EC / Maschineneinrichtung – Richtlinie 2006/42/EG Elektromagnetická kompatibilita – směrnice 2014/30/EU / Electromagnetic Compatibility Directive 2014/30/EU / Elektromagnetische Kompatibilität – Richtlinie 2014/30/EU Emise hluku – směrnice 2000/14/ES / Noise Emission Directive 2000/14/EC / Lärmemissionen – Richtlinie 2000/14/EG
Harmonizované technické normy a technické normy použité k posouzení shody / The harmonized technical standards and the technical standards applied to the conformity assessment / Harmonisierte technische Normen und für die Beurteilung der Konformität verwendete Normen:	ČSN EN ISO 12100, ČSN EN 500-1+A1, ČSN EN 500-4, ČSN EN ISO 4413, ČSN EN 13309
Osoby zúčastněné na posouzení shody / Bodies engaged in the conformity assessment / An der Konformitätsbeurteilung beteiligte Personen:	Notifikovaná osoba č. 1016 / Notified Body No.: 1016 / Notifizierte Stelle Nr.: 1016 Státní zkušebna strojů a.s., Třanovského 622/11, 163 04 Praha 6–Řepy, ČR. / The Government Testing Laboratory of Machines J.S.C., Třanovského 622/11, 163 04 Praha 6–Řepy, Czech Republic / Staatliche Prüfstelle für Maschinen AG, Třanovského 622/11, 163 04 Praha 6–Řepy, Tschechische Republik.
Použitý postup posouzení shody / To the conformity assessment applied procedure / Verwendetes Vorgehen der Konformitätsbeurteilung:	Na základě směrnice 2000/14/ES příloha VI / Pursuant to the Noise Emission Directive 2000/14/EC, Annex VI / Aufgrund der Richtlinie 2000/14/EG, Anlage VI
Naměřená hladina akustického výkonu / Measured sound power level / Gemessener Schalleistungspegel:	L _{WA} = 100 dB
Garantovaná hladina akustického výkonu / Guaranteed sound power level / Garantierter Schalleistungspegel:	L _{WA} = 101 dB

Místo a datum vydání / Place and date of issue / Ort und Datum der Ausgabe: Nové Město nad Metují,

Osoba zmocněná k podpisu za výrobce / Signed by the person entitled to deal in the name of manufacturer / Zeichnungsberechtigter für den Hersteller:

Jméno / Name / Name: Bc. Martin Čerovský
Funkce / Grade / Stelle: Quality Control Manager
Podpis / Signature / Unterschrift:

Congratulations on your purchase of an AMMANN road roller. This modern compaction device is characterised by simple operation and maintenance and is the product of many years of AMMANN experience in the field of road roller engineering. In order to avoid faults due to improper operation and maintenance we request that you read this operating manual with great care and keep it for later reference.

With kind regards,



Ammann Czech Republic a.s. | Náchodská 145 | CZ-549 01 Nové Město nad Metují

☎ + 420 491 476 111 | Fax + 420 491 470 215 | info@ammann-group.com | www.ammann-group.com

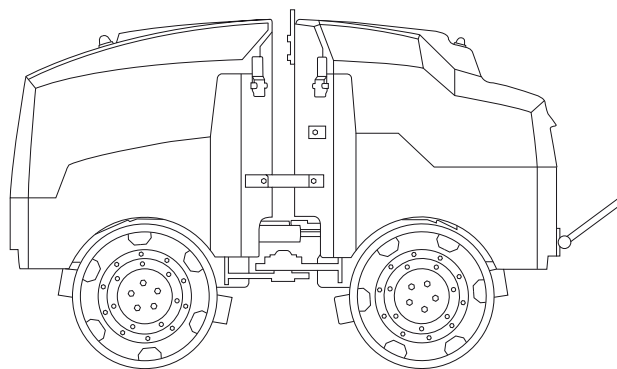

555002

This manual consists of:

I. Specification manual

II. Operating instructions

III. Maintenance manual

The following explanations serve to familiarise the machinist (operator) with the roller and to support him during handling and maintenance. It is therefore absolutely necessary to provide the operator with these instructions and to ensure that he reads them carefully before using the road roller. This aids training comprehension during the first use of the road roller.

Subsequent faults due to improper operating are avoided.

Adherence to maintenance instructions increases the reliability and lifetime of the machinery. It reduces repair costs and down time.

AMMANN accepts no liability for continued safe functioning of the road roller if it is incorrectly operated and / or operating modes are employed which represent improper use.

In order to ensure the smooth operation of AMMANN compaction equipment, use for repairs only the original spare parts supplied by AMMANN.

Preface

Information, specifications, and recommended operation and maintenance instructions contained in this publication are basic and final information at the time of the printing of this publication. Printer's errors, technical modifications, and modifications of figures are reserved. All dimensions and weights are approximate and, therefore, not binding.

Ammann Czech Republic a.s. reserves the right to perform modifications without obligation to inform the machine user. If you identify any differences between the machine operated by you and the information contained in this publication, contact your local dealer.

Reproduction or copying of any kind is prohibited without the written permission of Ammann Czech Republic a.s.

SYMBOLS OF THE SAFETY NOTICES:



The notice warns of a serious risk of personal injury or other personal hazards.



The notice warns of possible damages to the machine or its parts.



The notice warns of the necessity of environmental protection.

! NOTICE !

As used in this operating manual, the terms „right“, „left“, „front“ and „rear“ indicate the sides of the machine moving forward.

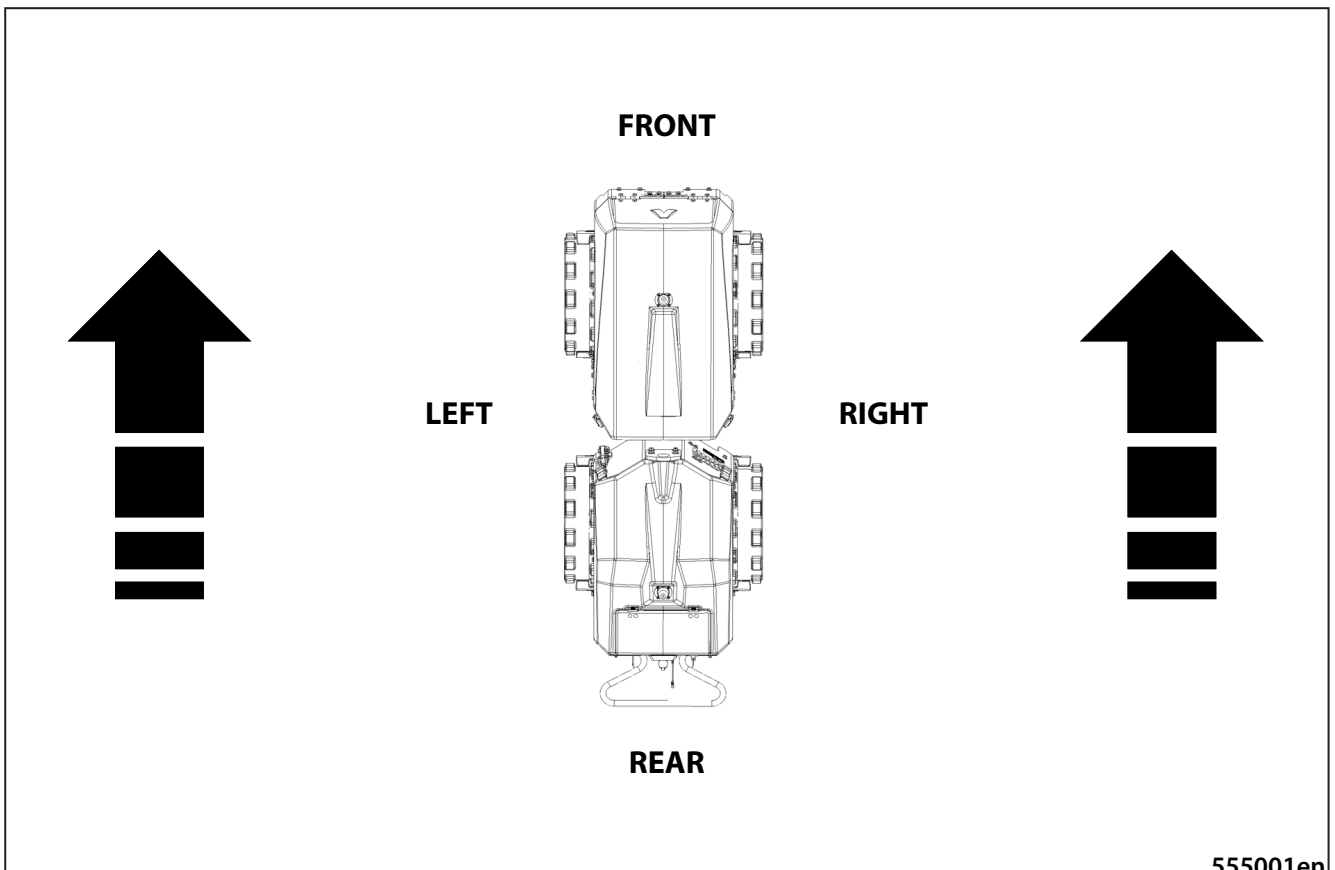

555001en

Content

Content	4
1. SPECIFICATION MANUAL	9
1.1. Basic Data	10
1.2. Dimension Chart	12
1.3. Technical Data	13
2. OPERATION MANUAL	17
2.1. Major Safety Precautions	19
2.1.1. Safety Measures during Machine Operation	19
2.1.1.1. Compaction Work Commencement	19
2.1.1.2. Work Safety Secured by User.....	19
2.1.1.3. Assurance of safety measures by the operator	20
2.1.2. Requirements on qualification of operating personnel	20
2.1.3. Driver's obligations.....	21
2.1.4. Forbidden activities – safety and guarantee.....	22
2.1.5. Safety notices and signs applied on the machine	23
2.1.6. Safety notices and signs applied on the infrared remote control.....	28
2.1.7. Hand signals	29
2.2. Environmental and hygienic principles	32
2.2.1. Hygienic principles.....	32
2.2.2. Ecological principles.....	32
2.3. Machine preservation and storage	33
2.3.1 Short-term preservation and storage for a period of 1–2 months	33
2.3.2. Preservation and storage for a period longer than 2 months	33
2.3.3. Putting the machine into operation after storage.....	34

2.4. Disposal of the machine at the end of its service life	35
2.5. Machine description.....	36
2.6. Actuators and dashboard instruments.....	40
2.6.1. Display unit	41
2.6.2. Infrared remote control	45
2.6.3. Light indication.....	58
2.7. Machine control and use	59
2.7.1. Commissioning.....	59
2.7.2. Protective cover.....	60
2.7.3. Start-up of the engine.....	61
2.7.4. Driving and braking.....	63
2.7.5. Turning off the engine	66
2.7.6. Machine parking	66
2.7.7. Opening the front and rear bonnets	67
2.7.8. ACEecon system	68
2.7.9. Roller overturning	69
2.8. How to transport the Machine.....	76
2.8.1. Machine loading	77
2.8.1.1. Loading the machine using a ramp	77
2.8.1.2. Loading the machine using a crane	78
2.9. Special conditions of the Machine use.....	80
2.9.1. Machine operation during running-in.....	80
2.9.2. Machine operation at low temperatures.....	80
2.9.3. Machine operation under high temperatures and humidity	81
2.9.4. Machine operation at higher altitudes	81
2.9.5. Machine operation in very dusty environment	81
2.9.6. Driving with vibrations on compacted and hard materials.....	81
2.10. Optional equipment.....	82
2.10.1. Shutdown bar.....	82
2.10.2. Drum extension set.....	82
2.10.3. Filter set 500 operating hours	83
2.10.4. Cover tarpaulin	83

Content

3. MAINTENANCE MANUAL	87
3.1. Safety and other measures for machine maintenance	89
3.1.1. Safety of machine maintenance.....	89
3.1.2. Fire protection measures during exchanges of operating fluids	89
3.1.3. Ecological and hygienic principles	90
3.2. Specification of fluids	91
3.2.1. Engine oil	91
3.2.2. Fuel.....	92
3.2.3. Coolant	93
3.2.4. Hydraulic oil.....	94
3.2.5. Lubricating grease.....	94
3.3. Fills.....	95
3.4. Lubrication and Maintenance Chart	96
3.5. Lubrication and service plan	98
3.6. Individual Operations of Maintenance	99
Every 10 hours of operation (daily).....	100
3.6.1. Checking fuel level.....	100
3.6.2. Engine oil level check.....	101
3.6.3. Engine cooling liquid level check	102
3.6.4. Hydraulic tank oil level check.....	103
3.6.5. Cleaning the hydraulic oil cooler	104
3.6.6. Air filter check	105
3.6.7. Cleaning of the water separator.....	106
3.6.8. Scrapers.....	106
3.6.9. Check of the near and remote halt function.....	107
3.6.10. Check of the safety bar function (optional equipment).....	108
Every 50 hours of operation	109
3.6.11. Inspection of brakes.....	109
3.6.12. Battery check.....	110
Every 100 hours of operation (weekly)	111
3.6.13. Lubricating steering cylinder, bearing	111
Every 250 operating hours (3 months)	112
3.6.14. Check of the fan and engine belt condition	112
3.6.15. Replacement of engine oil and filter.....	113

Every 500 hours of operation (6 months)	115
3.6.16. Replacement of fuel filters.....	115
3.6.17. Air filter cartridge replacement	117
Every 1000 hours of operation (1 year).....	119
3.6.18. Exchanging hydraulic oil and filter	119
3.6.19. Engine cooling liquid change.....	121
3.6.20. Cleaning the fuel tank.....	122
3.6.21. Valve clearance adjustment	123
3.6.22. Check of swing support.....	123
3.6.23. Check of articulation joint	124
3.6.24. Checking the damping system	124
Maintenance - As Needed	125
3.6.25. Replacement of engine cover gas struts	125
3.6.26. Cleaning the machine.....	126
3.6.27. Check of the screw connection tightening	127
3.7. Defects.....	129
3.8. Annexes	130
3.8.1. Wiring diagram	130
3.8.2. Hydraulic system diagram	132
3.8.3. Table of spare parts	134

1. SPECIFICATION MANUAL

ARR 1575

(Yanmar Tier 4 Final)

1.1. Basic Data

Machine description

The ARR 1575 trench roller is a roller specially designed for trench compacting. The unlimited side clearance of the roller drums allows compacting in very narrow, tight trenches right up to the trench walls.

Machine application

The wet, clayey soils found in sewer construction, pipeline construction, road foundations and construction backfilling, etc., are the areas of application for this modern trench roller. In hazardous construction site applications, it is possible for the operator to control the machine from a safe distance with no personal risk.

Only use the ARR 1575 roller for driving on and compacting of non-cohesive (loose) materials.

The machines are intended for operation in conditions of the following types according to ČSN IEC 721-2-1 (038900): WT, WDr, MWDr (i.e. mild, warm dry, hot dry with a limited temperature range of from -15 °C (5 °F) to +45 °C (113 °F).

Please fill in the following data:
(see Pin label, Label of the Yanmar engine)

Type of machine
.....

ICV/PIN (Serial number of the machine)
.....

Production year
.....

Type of engine
.....

Serial number of the engine
.....

Please refer to the data in the table below always when approaching the dealer or the manufacturer.

The machine that complies with the requirements as to health protection and safety is identified with a name plate with CE marking.

- 1 - Name – always mentioned only in the English version
- 2 - Type
- 3 - Serial number
- 4 - Operating weight
- 5 - Maximum weight
- 6 - Rated power
- 7 - Version
- 8 - Shipping weight
- 9 - Front axle load
- 10 - Rear axle load
- 11 - Year of manufacture



Name plate location

- 1 - Name plate
- 2 - Machine frame number



Engine name plate location



1.2. Dimension Chart

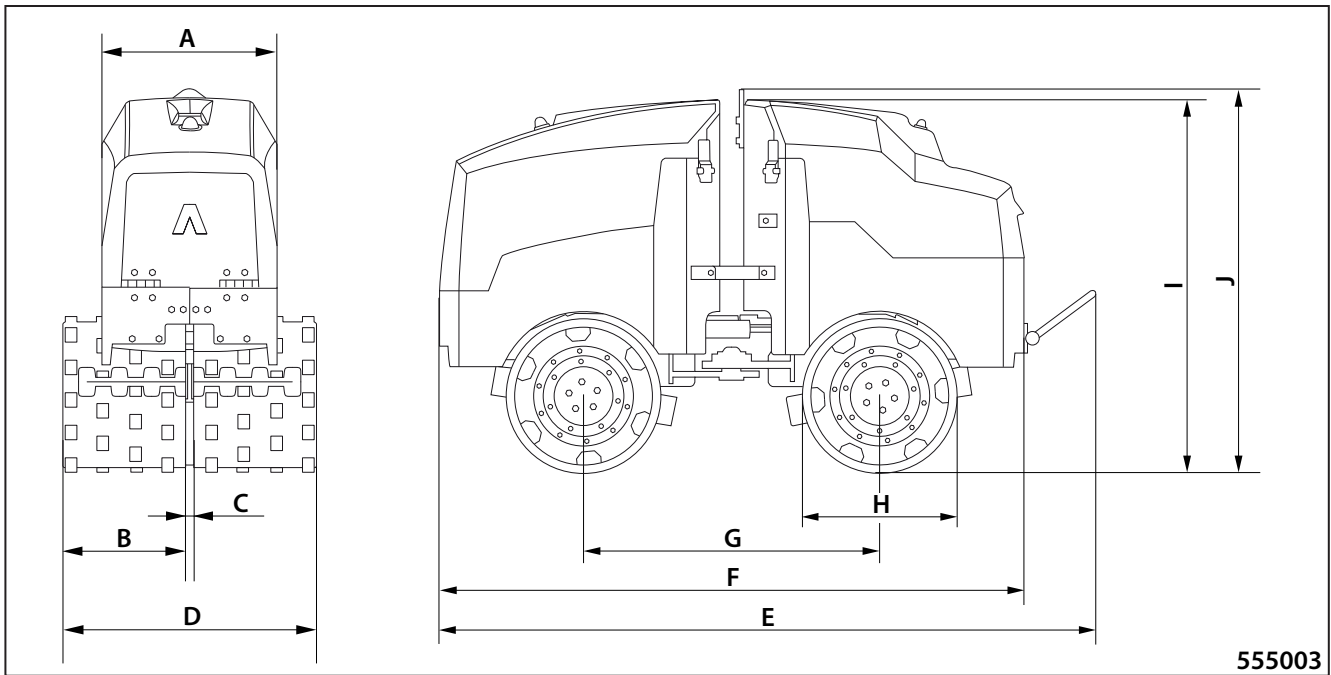

mm (in)		A	B	C	D	E	F	G	H	I	J
ARR 1575 T4 final	640	601	302	36	640	2227	1980	1000	525	1282	1317
		(23,7)	(11,9)	(1,4)	(25,2)	(87,7)	(78,0)	(39,4)	(20,7)	(50,5)	(51,9)
	850	601	407	36	850	2227	1980	1000	525	1282	1317
		(23,7)	(16,0)	(1,4)	(33,5)	(87,7)	(78,0)	(39,4)	(20,7)	(50,5)	(51,9)

1.3. Technical Data

		ARR 1575 Tier 4 final	
		640	850
Dimension			
Drum width	(mm)	640	850
Weight			
Operating weight of EN 500-1+A1 (CECE)	kg (lb)	1340 (2950)	1440 (3170)
Operating load of EN 500-1+A1 (CECE) on front axis	kg (lb)	730 (1610)	780 (1720)
Operating load of EN 500-1+A1 (CECE) on rear axis	kg (lb)	610 (1340)	660 (1460)
Weight of half fluid capacities	kg (lb)	10 (20)	10 (20)
Operating weight of ISO 6016	kg (lb)	1350 (2980)	1450 (3200)
Maximum weight with accessories	kg (lb)	1350 (2980)	1450 (3200)
Driving characteristics			
Maximum transport speed	km/h (MPH)	2,8 (1,7)	2,8 (1,7)
Working speed		1,4 (0,9)	1,4 (0,9)
Climbing ability without vibration	%	30	30
Climbing ability with vibration	%	25	25
Lateral static stability	%	80	80
Lateral stability during driving without vibration	%	25	25
Lateral stability during driving with vibration	%	15	15
Turning radius inner (edge)	mm (in)	1540 (60,6)	1440 (56,7)
Turning radius outer (contour)	mm (in)	2190 (86,2)	2290 (90,2)
Type of drive	-	Hydrostatic	
Number of driving axles	-	2	
Oscillation angle	°	± 7	
Angle of steering	°	± 30	
Steering			
Type of steering	-	Joint	
Steering control	-	Hydraulic	
Linear hydraulic motors	-	2	
Engine			
Manufacturer	-	YANMAR	
Type	-	3TNV80F-SPAMM	
Power according to ISO 3046-1	kW (HP)	14,6 (20)	
Number of cylinders	-	3	
Cylinder capacity	cm ³ (cu in)	1266 (77)	
Nominal speed	min ⁻¹ (RPM)	2400	
Maximum torque	Nm (ft lb)/rpm	68,4/1800	
Average fuel consumption	l/h (gal US/h)	3,2 (0,8)	
Engines complies with emission regulations	-	U.S. EPA Tier 4 Final	
Cooling system of engine	-	Liquid	
Brakes			
Operating	-	Hydrostatic	
Parking	-	Mechanical multiple-disc	

1.3. Technical Data

		ARR 1575 Tier 4 final	
		640	850
Vibration			
Frequency I	Hz (VPM)	40 (2400)	
Amplitude I	mm (in)	0,6 (0,024)	
Amplitude II	mm (in)	1,1 (0,043)	
Fluid capacities			
Fuel	l (gal US)	28 (7,4)	
Engine (oil filling)	l (gal US)	3,4 (0,9)	
Cooling system	l (gal US)	1,2 (0,3)	
Hydraulic system	l (gal US)	16 (4,2)	
Wiring			
Voltage	V	12	
Battery capacity	Ah	77	
Noise and vibration emissions			
Measured sound power level A, L_{pA} at the operator's position *	dB	70	
Uncertainty K_{pA} *	dB	1	
Guaranteed sound power level A, L_{WA} **	dB	101	
Optional equipment			
Safety bar			
Drum extension set			
Scrapers			
Filter set 500 operating hours			
Cover tarpaulin			

* measured according the EN 500-4

** measured according the DIRECTIVE 2000/14/EC

Notes

2. OPERATION MANUAL

ARR 1575

(Yanmar Tier 4 Final)

2.1.1. Safety Measures during Machine Operation

Safety measures given in the individual chapters of Engineering Documentation supplied with the Machine shall be added with Safety Precautions in force within a respective country that uses the Machine at workplace with regard to work organization, work process and personnel involved.

2.1.1.1. Compaction Work Commencement

- Constructional Supplier (Machine User) is liable to issue instructions for driver and maintenance before compaction work is started, that will include requirements on work safety provision during Machine operation.

- He must verify and mark:
 - utility lines
 - underground areas (direction, depth)
 - seepage or escape of hazardous materials
 - soil bearing capacity, slope of travelling plane
 - other obstructions incl. their removal.

He must make Machine driver, who will carry out earth work, familiar with these conditions.

- He must specify Code of Practice (C.O.P.) part of which is work procedure for a given work operation and this work procedure will specify inter alia:
 - measures when working under extraordinary conditions (work within protective zones, within extreme slopes, etc.)
 - precautions for any natural disaster hazards
 - requirements on work performance while observing job safety principles
 - technical and organizational measures to secure safety of personnel, workplace and environment.

He must make Machine driver evidently familiar with the Code of Practice.

2.1.1.2. Work Safety Secured by User

- User shall promptly communicate any damage to the utility lines to their operator, and at same time he make measures to prevent unauthorized persons from entering endangered area.
- He must ensure an employee does not work alone at a workplace. Another worker must always be in sight and within an ear-shot, who in case of accident will provide or call for help unless another effective form of monitoring or communication exists.

2.1. Major Safety Precautions

2.1.1.3. Assurance of safety measures by the operator

- The operator must ensure that the machine is operated only under conditions and only for purposes it is technically capable of according to the conditions set by the manufacturer and the respective standards.
- The operator must ensure using the machine in such a way and in such worksites where there is no risk of hazardous transmitting of vibrations and damage to nearby buildings etc.
- The operator must ensure regular inspection of operation and technical conditions, regular maintenance of the machine in intervals specified in the manuals for lubrication and maintenance. If the technical condition of the machine does not meet requirements to such an extent that it poses a risk to safety of operations, persons and property, or damages and harms the environment, the machine must be put out of service until the defects are removed.
- He must specify who is allowed to carry out operation, maintenance and repairs of the machine as well as what activities can be carried out during the operation, maintenance and repair of the machine.
- Every person who drives the machine or performs maintenance and service of the machine must be familiarised with instructions stipulated in the operation manual of the machine.
- The operator must ensure that the fire extinguisher is checked on regular basis.
- The operator must ensure that the „Operation manual“ is available at the designated place in the machine.
- The operator must ensure continuous supervision by an appointed person during machine operation on public roads, and he is especially liable for releasing instructions to ensure health protection and work safety.
- The operator must ensure removal of spilled hazardous materials (fuel, oil, cooling liquid, brake fluid, etc.) from the places of spillage, depending on their nature, so as to avoid their adverse impact on the environment, safety of operation and human health.

2.1.2. Requirements on qualification of operating personnel

- The machine can only be driven by a person who has been trained according to ISO 7130 and other local and national instructions and standards specified for drivers of this group of machines.

2.1.3. Driver's obligations

- Prior to start of the machine operation, the driver is obliged to study instructions stated in the documentation supplied together with the machine, especially with safety precautions. The driver is obliged to observe such instructions very strictly. The same applies to personnel appointed with maintenance, adjustment and repairs of the machine. (In case you do not understand some parts of the manuals, contact the nearest dealer or the manufacturer.)
- The driver must only drive the machine if he is fully familiarized with all its functions, operating and control elements and if he knows exactly how to operate the machine.
- The driver is obliged to follow the safety symbols placed on the machine and keep them legible.
- Before starting the work, the driver must get familiar with the worksite environment, i.e. with obstructions, gradients, utility lines, with necessary types of workplace protections with respect to the surroundings (noise, vibrations, etc.).
- When a risk to health or life of persons or a risk to property is detected, or in the case of defect of the technical equipment or if symptoms of such risks are found during operation, the driver, unless he is able to remove such risks on his own, must stop the work and secure the machine against incidental start, report the case to the person in charge and notify all persons exposed to the detected risk.
- Prior to starting the machine operation, the driver is obliged to acquaint himself with records and operational deviations found during the previous working shift.
- Prior to starting work, the driver is obliged to inspect the machine and accessories, to check its controls, communication and safety equipment and to make sure that they are functional in accordance with the manual. When the driver detects a defect that might endanger the safety of work and that he is not able to repair, he must not put the machine into operation and must report such defect to the worker in charge.
- When the driver detects a defect during operation, he must stop the machine immediately and secure it against incidental start.
- During operation, the driver must observe the function of the machine and to record any detected defects into the log of operation.
- The driver must maintain the log of operation, which is designed for keeping records on the machine take-over and hand-over between individual drivers and on defects occurring and repairs carried out during operation as well as for recording major events occurring during a working shift.
- Prior to starting the machine operation, the driver must check the function of the brakes and the steering.
- Before the engine is started, the controls must be in their zero positions and no persons are allowed to stay within dangerous reach of the machine.
- The driver must signal every machine start with the acoustic or light signal, always before the engine is started.
- After issuing the warning alarm, the driver may only start the machine when all workers have left the endangered area. During operation of the machine it is necessary to follow safety instructions and not to carry out any activity that might jeopardise work safety. The driver must be fully engaged in driving the machine.
- The driver must comply with technological procedures of works or instructions of the worker in charge.
- When rolling the machine on the worksite, the driver must adjust the driving speed to terrain conditions, to the type of work performed and to weather conditions. The driver must always watch the passage clearance to prevent collision with any obstacle.
- In case the driver finishes or interrupts the machine operation and leaves the machine, he must take safety measures to prevent any unauthorized use of the machine and incidental start. The driver must remove the key from the ignition box, lock the cab and disconnect the wiring using the disconnecter.
- When the operation is completed, park the machine at a suitable parking place (flat with sufficient bearing capacity) to ensure stability of the machine; the machine must not interfere with traffic roads, must not be exposed to falling objects (rocks), and must be protected against any natural risks of another kind (floods, landslides, etc.).
- When the machine is abandoned on traffic roads, measures must be taken according to corresponding traffic rules. The machine must be marked properly.
- After finishing the work with the machine, all defects, damage to the machine and any repairs made must be recorded in the log of operations. When drivers take turns, the driver is obliged to inform the following driver about any observed issues.
- The driver must use personal protective equipment fit for the work performed - work clothes, working shoes, helmet, gloves and safety glasses.
- The driver must keep the machine equipped with specified accessories and equipment.
- Keep the machine clean.
- Keep the machine free of oil contaminants and inflammable materials.
- If the machine comes into contact with high voltage, observe the following principles:
 - try to leave the hazardous zone with the machine
 - warn the others to keep off and not touch the machine.

2.1. Major Safety Precautions

2.1.4. Forbidden activities – safety and guarantee

It is prohibited:

- To use the machine in a case of an obvious defect.
 - To use the machine when the level of any operating fluid is low.
 - To repair the engine without authorization – except common changes of operating fluids and filters, only an authorized service organization is allowed to intervene in the engine, including the peripheral components of the engine (for example, the alternator, the starter, the thermostat, the electrical installation of the engine).
 - To operate the machine in explosive atmosphere and underground.
 - To use the machine under the influence of alcohol or drugs.
 - To use the machine if its operation might pose risk to its technical condition, to safety (life, health) of persons, to facilities or objects or to road traffic and its fluency.
 - To put the machine into operation and use it when other persons are within its hazardous reach – the exception is training of a driver by an instructor.
 - To put the machine into operation and use the machine when any of its safety devices has been removed or is damaged.
 - To drive the machine and use it for compacting at such slopes where the machine stability would be breached (overturning). The stated machine static stability is reduced by dynamic effects of driving.
 - To drive the machine and use it for compacting at such slope angles where there is hazard of soil breaking off under the machine or a risk of a loss of adhesion and uncontrolled skidding.
 - To control the machine in any other way than stated in operation manual.
 - To drive and compact with vibration in such a distance from the slope edge or trenches where there is a hazard of landslide or shoulder breaking off with the machine.
 - To drive and compact with vibration in such a distance from walls, cuts and slopes where their collapse could occur and the machine could be buried under.
 - Driving with vibration on hard (frozen, concrete, overcompacted) surface or on bedrock. There is a danger of damage to the machine.
 - To compact with vibration in such a distance from buildings, facilities or equipment, within which risk of their damage due to vibration could occur due to the transmission of vibrations.
 - To move and transport persons on the machine.
 - To operate the machine with the bonnet lifted off.
 - To operate the machine if there are other machines or means of transport within its hazardous reach, except those that operate in mutual cooperation with the machine.
 - To operate the machine at a place that is not seen from the driver's stand and where hazard to people or property could occur unless work safety is ensured by another way, e.g. with mediate signalling by a duly instructed person.
- To operate the machine in a protected zone of electric lines or substations.
 - Do not cross electric cables if they are not properly protected against mechanical damage.
 - To operate the machine at reduced visibility or at night, unless the machine's working area and the workplace are sufficiently illuminated.
 - To sit on the railing or on the outside parts of the machine when driving.
 - To leave the machine unattended – to move away from the machine without having prevented its misuse.
 - To disable safety, protective or locking systems or alter their parameters.
 - To use the machine with leaking oil, fuel, cooling liquid or other fillings.
 - To start the engine in a different way than specified in the operation manual.
 - To lay materials or other objects on the machine.
 - To remove dirt while the machine is running.
 - To perform maintenance, cleaning or repairs when the machine is not secured against spontaneous move or accidental start and when contact of a person with moving parts of the machine is not excluded.
 - To touch moving parts of the machine with the human body or objects and tools held in hands.
 - To smoke or handle a naked flame when checking or pumping fuels, exchanging or refilling oils, lubricating the machine and inspecting or refilling the accumulator.
 - To carry rags saturated from inflammable materials and inflammable liquids in unbound/loose vessels on the machine (in the engine space).
 - To run the engine inside a closed area. Exhaust fumes are dangerous to life.
 - To perform any adjustments on the machine without the prior consent of the manufacturer.
 - To move electrical conductors.
 - To use other than original spare parts.
 - To intervene in the electrical and electronic units in any manner.
 - To fill the hydraulic circuit during the guarantee period in a different way than using the hydraulic unit.



Breaching these provisions can influence the evaluation of a possible complaint and effect of the machine guarantee period.

2.1.5. Safety notices and signs applied on the machine

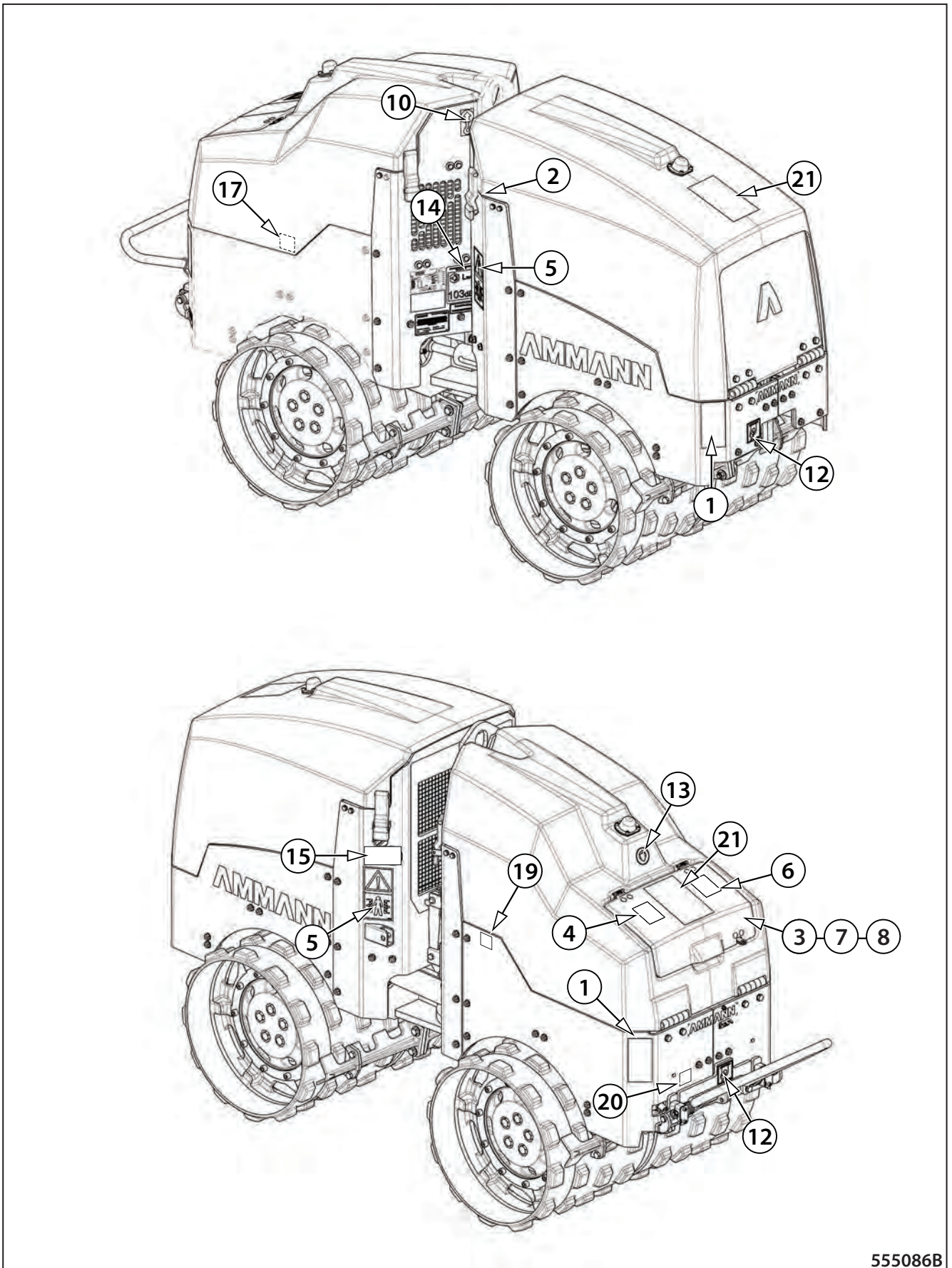

555086B

2.1. Major Safety Precautions

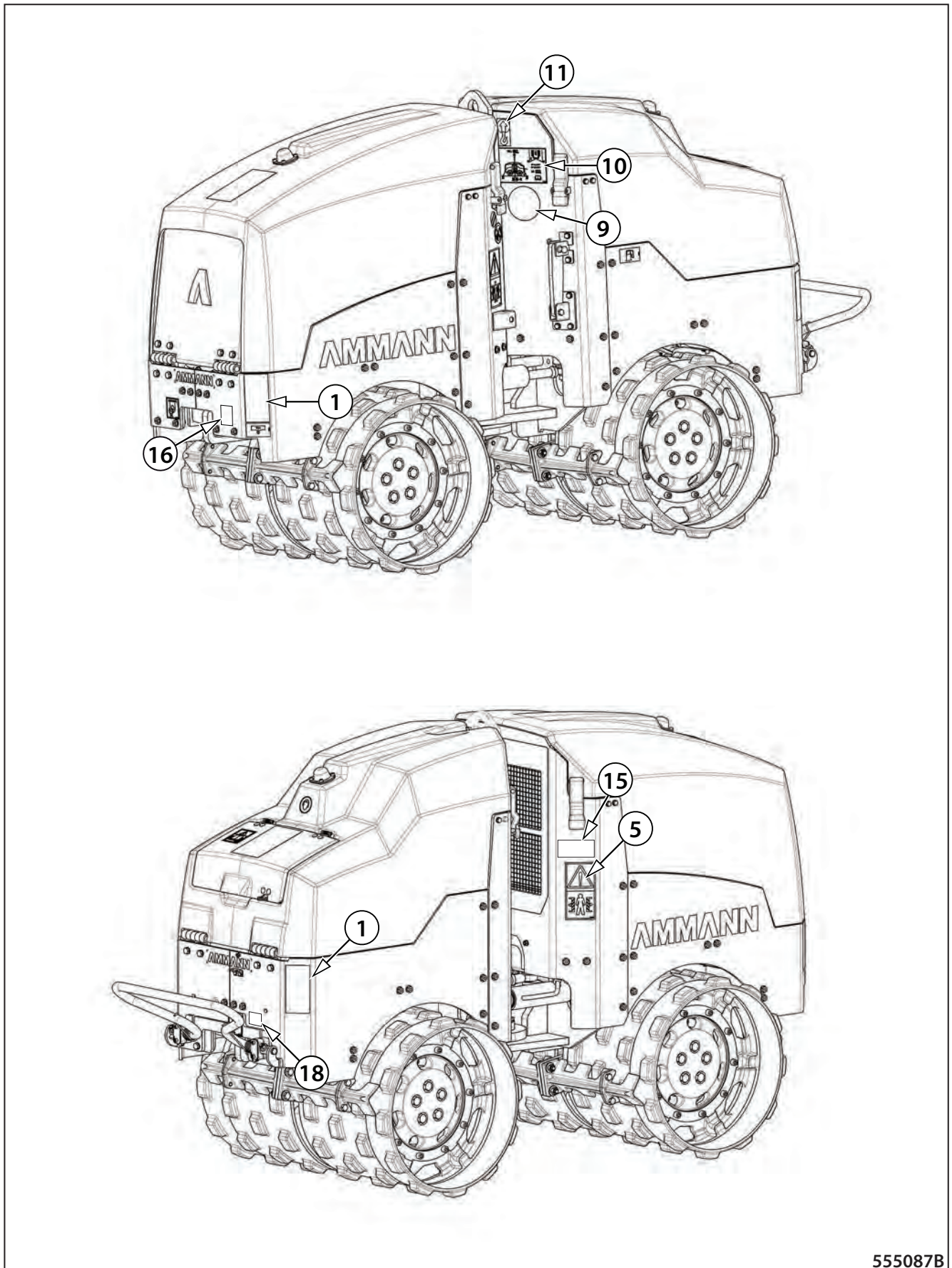

555087B

1 Runover hazard



3842

Keep clear of machine, runover hazard.

2 Injury hazard



3866

Risk of injury: There is a risk of injury! Do not touch rotating parts of the machine while the engine is running. There is a risk of burns. Do not touch hot parts of the machine unless you make sure that they have cooled down sufficiently.

3 Machine overturning



3873

Do not start the machine that has turned over.

4 Read Operation manual



2946bz

Get familiar with operation and maintenance of the machine from the Operation Manual!

5 Hazardous area



3865

Keep clear of machine, there is a risk of being squeezed between the front and rear frame of the machine.

6 Adjust while at rest



2584bz

Switch OFF the engine and remove the key from ignition box before carrying out any maintenance or repair.

7 Proper use of the infrared remote control



3839

Get perfectly familiar with the machine operation according to the operation manual.

2.1. Major Safety Precautions

8 Ignition

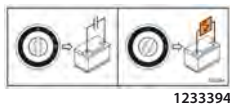

Get perfectly familiar with the machine operation according to the operation manual.

9 Sets of filters

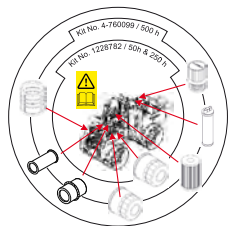

10 Lifting diagram

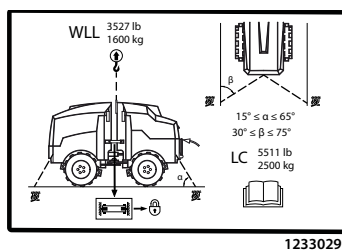

To lift the machine, use binding means of sufficient loading capacity according to the Machine loading chapter. Before lifting, lock the articulation of the machine.

11 Lifting lug



To lift, suspend the machine on these lugs only.

12 Tying lug



Use only these lugs to tie the machine during transport.

13 Ear protection



Dangerous noise level! Use ear protection.

14 Guaranteed acoustic power level

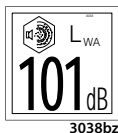

15 Washing the machine by water

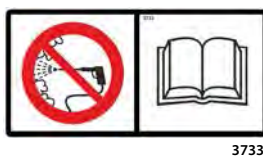

Dangerous situation. Prevent water from entering the electric and electronic parts of the machine as it could result in damage to the equipment and injury of persons. Read Operation Manual!

16 Engine oil draining plug



17 Hydraulic oil level



3874

18 Hydraulic oil draining plug



3960

19 Fuel tank



2151bz

20 Fuel draining plug



3213

21 Diagram of the protected and the safe zone



3876

Get perfectly familiar with the machine operation according to the operation manual.

22 Coolant



3953
3953bz

Use the coolant of required specification according to Chapter 3.2.3.

2.1. Major Safety Precautions

2.1.6. Safety notices and signs applied on the infrared remote control



Sensor cleanliness



Do not cover the sensors

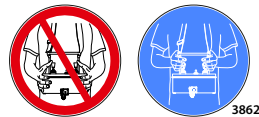

Thoroughly familiarize yourself with the use of the infrared remote control according to the operating manual! The side and front diodes of the infrared remote control must not be covered (e.g. by fingers, hand, foreign objects or dirt).

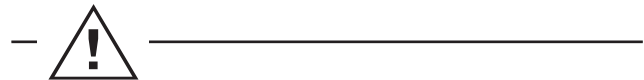

Regularly clean the solar panels and the side and front diodes of the infrared remote control.

2.1.7. Hand signals

- Signals given by an assistant operator if the driver cannot see the travelling or working area or machine work devices.
- The following principles must be observed:
 - Only a limited number of signals must be used for communication purposes.
 - The signals must be easily distinguishable to prevent confusion.
 - Hand signals can only be used in case the environmental conditions support clear communication between persons.
 - Hand signals must be as similar as possible to intuitive movements.
 - One-hand signals can be given by any hand.

EXAMPLES OF COMMUNICATION SIGNALS:

Engine start

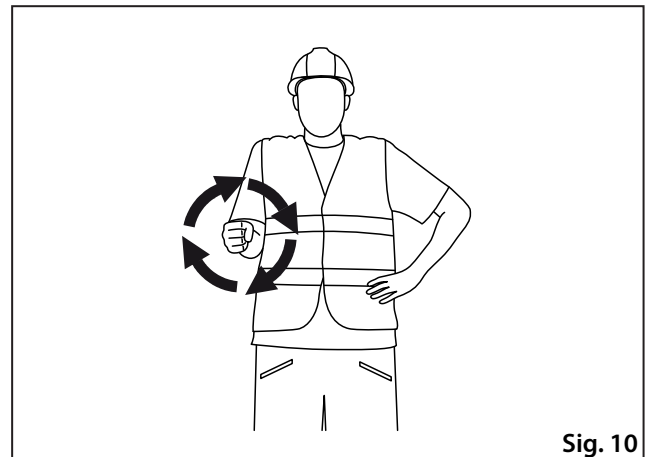

Engine stop

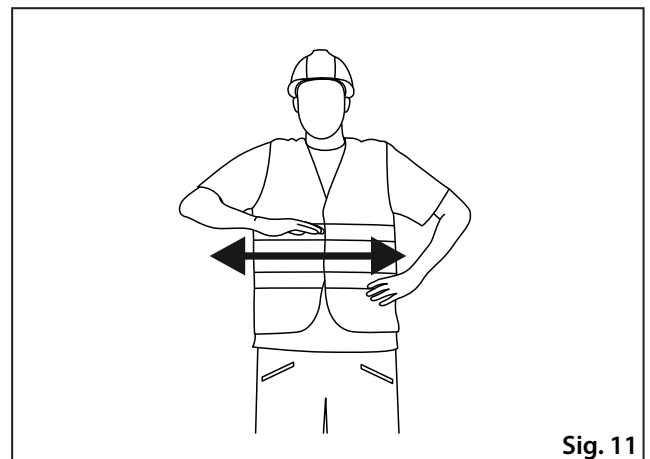

Stop

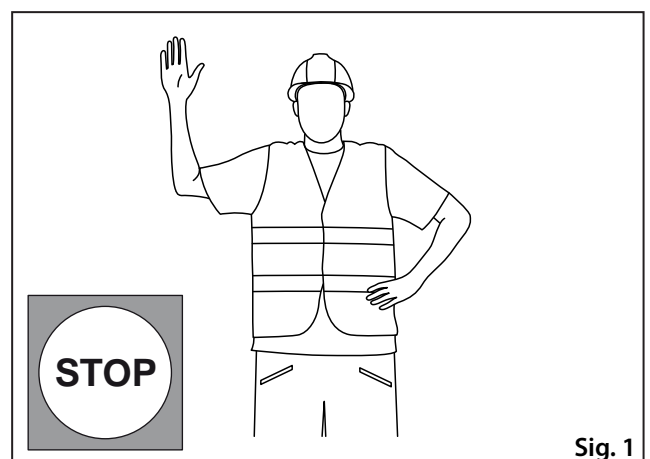

2.1. Major Safety Precautions

Watch out

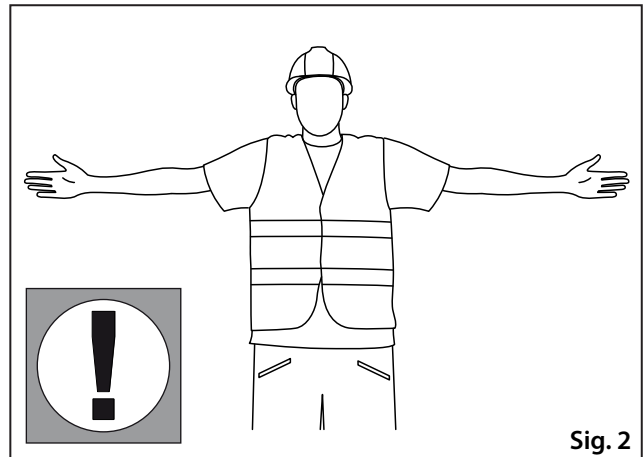

Fig. 2

Watch out, danger

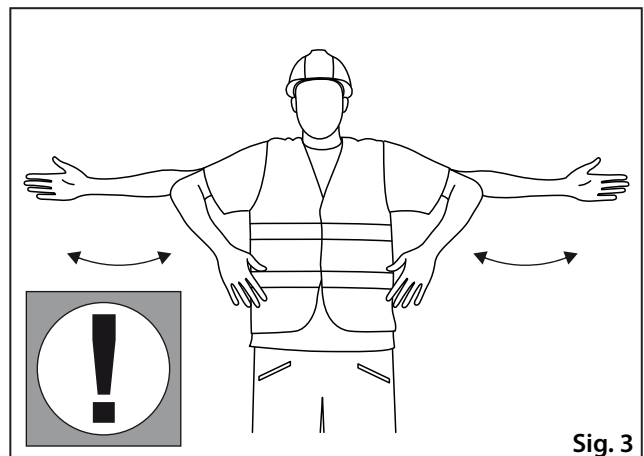

Fig. 3

Driving

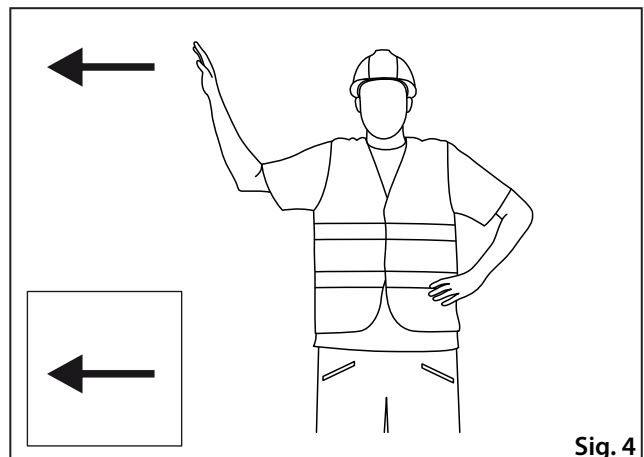

Fig. 4

Slow driving forward - towards me

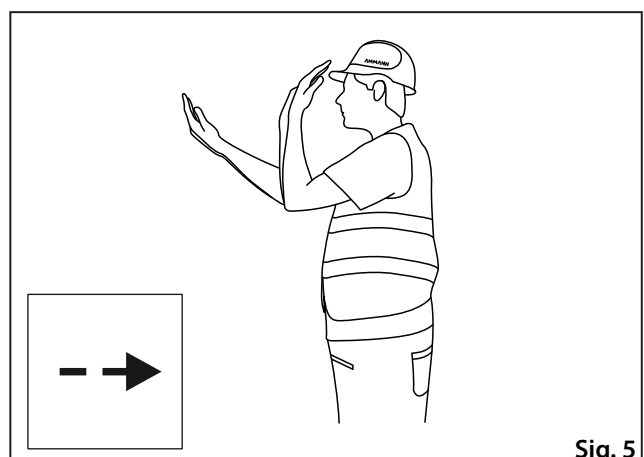
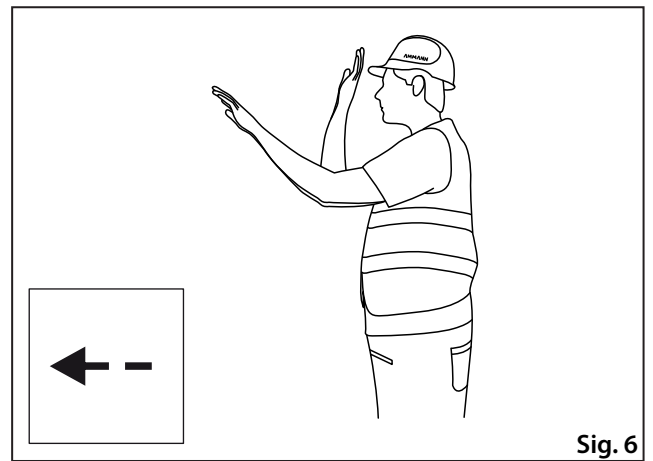

Fig. 5

Slow driving backward - away from me



Sig. 6

Driving to the right

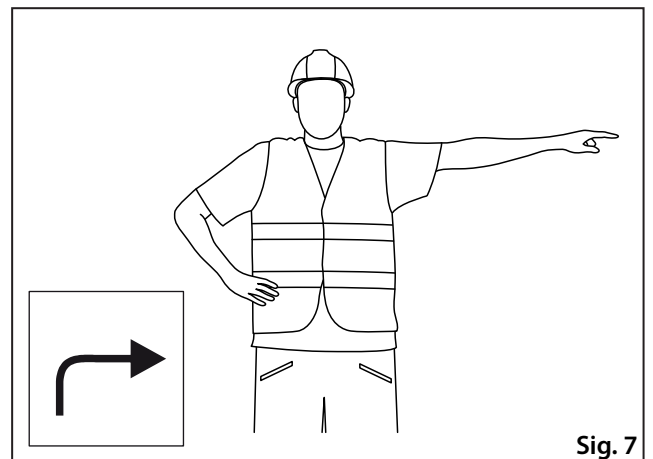

Sig. 7

Driving to the left

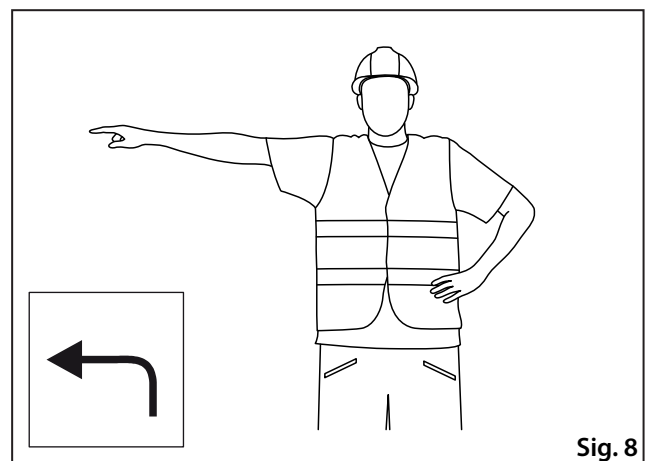

Sig. 8

Short-distance driving

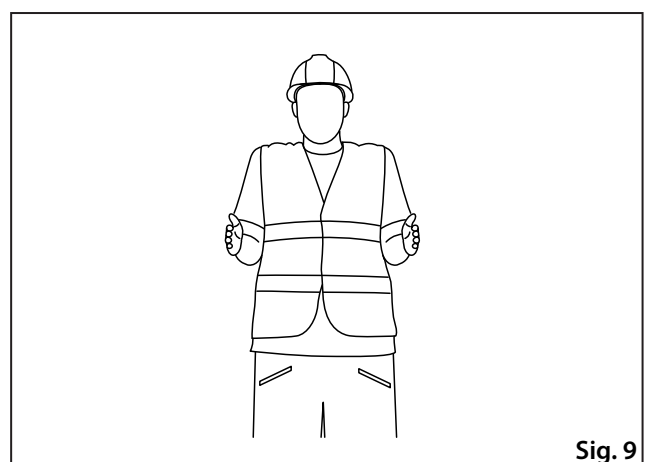

Sig. 9

2.2. Environmental and hygienic principles

2.2.1. Hygienic principles



When operating and storing the machines, the user is obliged to observe general principles of health and environmental protection, and laws and regulations relating to the given issues and in force within the territory where the machine is used.

- Petroleum products, cooling system fillings, battery fillings and coating compounds, including solvents, are materials harmful to health. Workers coming into contact with these products during machine operation or maintenance are obliged to follow general principles of their own health protection and comply with safety and hygienic manuals by manufacturers of these products.

In particular we draw your attention to the following:

- Protect your eyes and skin while working with the batteries
- Protect your skin while working with petroleum products, coating compositions and coolants
- Wash your hands properly after finishing the work and before the meal, treat the hands with appropriate repairation cream
- When handling cooling systems, please follow the instructions given in the manuals delivered with the machine.
- Always store petroleum products, coolants and batter fluids, coating compounds, incl. organic solvents, as well as cleaning and preserving agents in their original and properly labelled packages. These materials are not allowed to be stored in unlabelled bottles or in any other vessels considering the possible risk of confusion. Possible confusion with foodstuffs or beverages is very dangerous.
- In case of accidental contact with skin, mucosa and eyes or inhalation of vapours, immediately apply the first aid. In case of accidental ingestion of these products, seek medical help immediately.
- When operating the machine that is not provided with a cab or when the cab windows are open, always use ear protectors of suitable type and version.

2.2.2. Ecological principles

- The fillings of individual systems of the machine and some of its parts become hazardous waste for the environment when discarded.

This category of waste products includes in particular:

- Organic as well as synthetic lubricating materials, oil or fuels
- Coolants
- Battery media and batteries
- Cleaning and preservative agents
- All dismantled filters and filter cartridges
- All used and discarded hydraulic or fuel hoses, rubber-metals and other parts of the machine contaminated by the above mentioned products.



After the stated materials and parts are discarded, they must be handled in accordance with the respective national regulations on environmental protection and in accordance with the health protection regulations.

2.3. Machine preservation and storage

2.3.1 Short-term preservation and storage for a period of 1–2 months

- Wash and clean the entire machine carefully. Before parking the machine for preservation and storage, please warm up the engine to its operating temperature while running. Park the machine on solid, flat surface at a safe place with no risk of natural disaster (floods, landslides, fire, etc.) for the machine.
- In addition:
 - Repair damaged coating
 - Lubricate all lubrication points
 - Confirm that water fillings have been drained
 - Check that the coolant has the required antifreezing specification
 - Check charging of the accumulators and recharge them if necessary
 - Place the fully charged infrared remote control in a dry room and charge it up fully regularly every two months at least
 - Apply preservative grease over the chrome-coated surfaces of piston rods
 - We recommend you to protect the machine against corrosion by spraying the preservation agent, especially on places with a risk of corrosion.

2.3.2. Preservation and storage for a period longer than 2 months

- For machine shutdown, the same principles are applicable as for the short-term preservation.
- In addition it is recommended to:
 - Dismantle the accumulators, check their condition, and store in a cool, dry room (recharge the accumulators regularly)
 - Place the fully charged infrared remote control in a dry room and charge it up fully regularly every two months at least
 - Support the drum frame so that the shock-absorbing system shows minimal sag
 - Protect the rubber elements by coating with special preservative agent.
 - Blind the suction and exhaust pipe of the engine with double PE foil and tighten it carefully with sealing tape.
 - protect the headlamps, external back mirrors and other elements of external wiring through spraying a special agent and wrapping into PE foil
 - Preserve the engine according to the manufacturer's manual – place a visible mark that the engine is preserved.
- Always move the start / stop switch on the infrared remote control to the stop position.



After 6 months we recommend you to inspect the condition of preservation and renew if required.

Never start the engine during the storage!

When the machine is stored under field conditions, check that the parking place is not exposed to danger of flooding due to floods and that there is no other type of danger in this area (landslip etc.)!

If the infrared remote control is without light for a long time, it is necessary to charge it up fully every two months at least. Otherwise the accumulator can get damaged irreversibly.



Before restoring operation of the machine, wash off the preservation agents using high pressure stream of hot water with common degreasers while observing the operation manual and the ecological principles.

Remove the preservation film and wash the machine at places provided with intercepting sumps to trap the rinsing water as well as deconserving agents.

2.3. Machine preservation and storage

2.3.3. Putting the machine into operation after storage

- Check that some parts of the machine have not been damaged during storage and are not missing.



Remove preservation agents before putting the machine into operation:

Wash off the preservation agents using high pressure stream of hot water with common degreasers while observing the operation manual and the ecological principles.

Carry out removing of the preservation agents and washing the machine at places provided with intercepting sumps to trap the rinsing water as well as deconserving agents.

- Prepare the engine for operation according to the manual from the manufacturer.



Check the level of operating fluids before you put the machine into operation!

2.4. Disposal of the machine at the end of its service life

- During machine disposal at the end of its service life, the user is obliged to follow national waste treatment and environmental regulations and acts. In these cases, we recommend you to always contact:
 - specialized companies with respective authorization for these activities
 - the machine manufacturer or manufacturer-appointed accredited contracting service organizations.



The manufacturer Ammann shall not be liable for damage to the health of users or environmental damage caused by non-compliance with the above mentioned rules.

2.5. Machine description

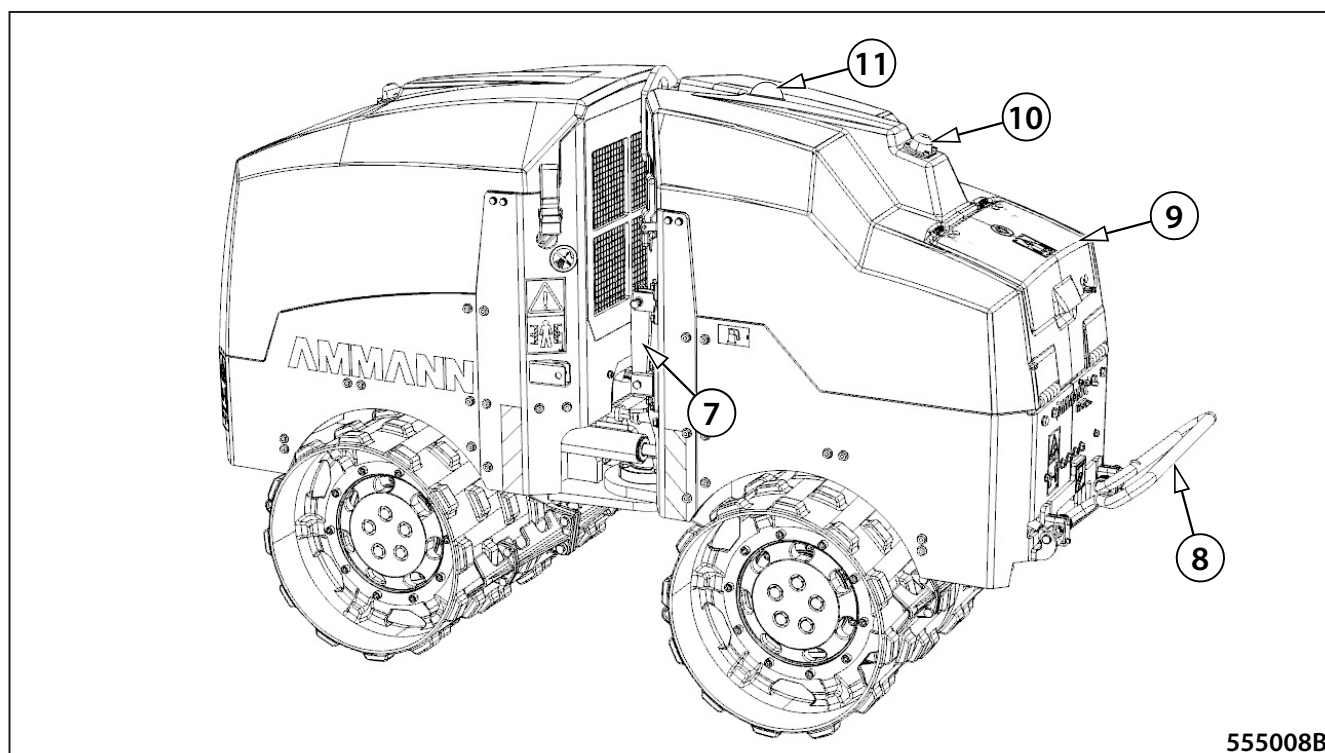
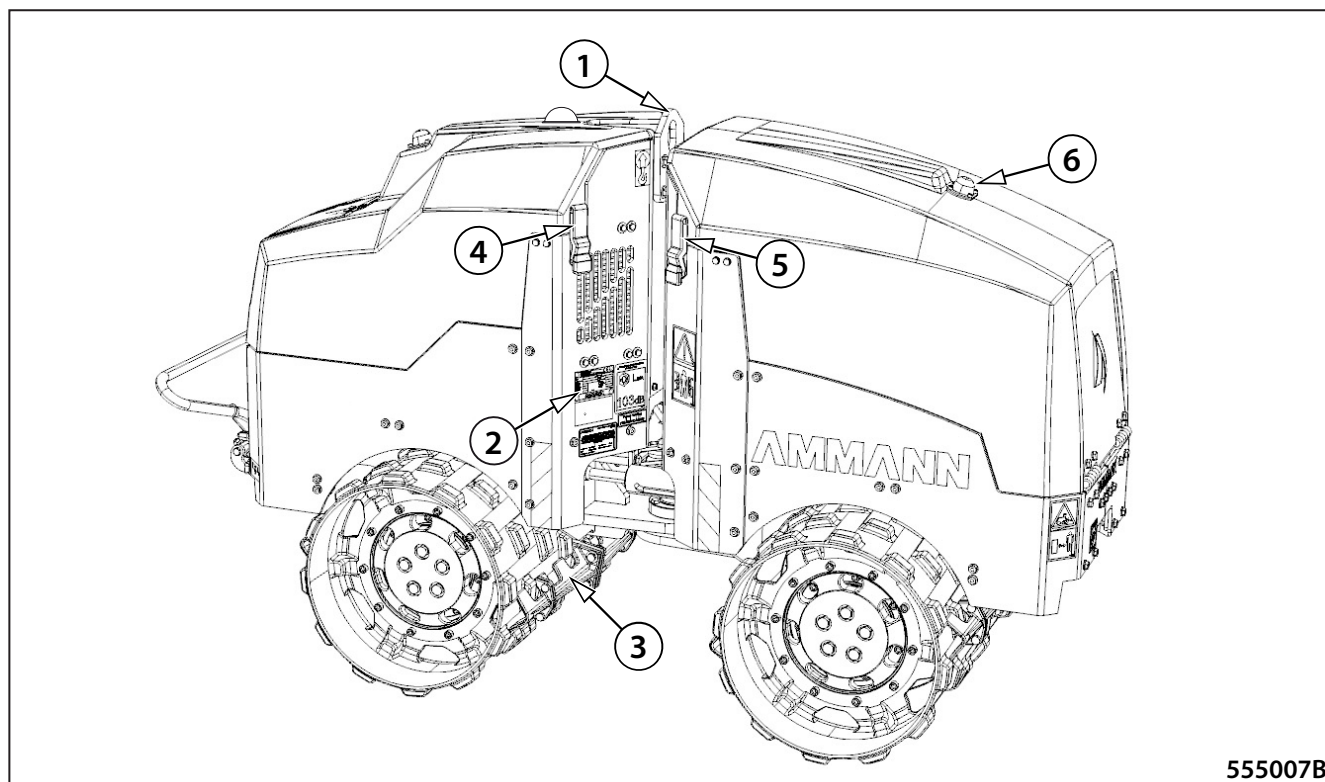

View from the right

- 1 - 1-point lifting eye
- 2 - Identification plate
- 3 - Drum scraper
- 4 - Rear bonnet closure
- 5 - Front bonnet closure
- 6 - Front infrared sensor

View from left

- 7 - Articulated joint protection
- 8 - Shutdown bar (optional)
- 9 - Cockpit cover
- 10 - Rear infrared sensor
- 11 - Light indication

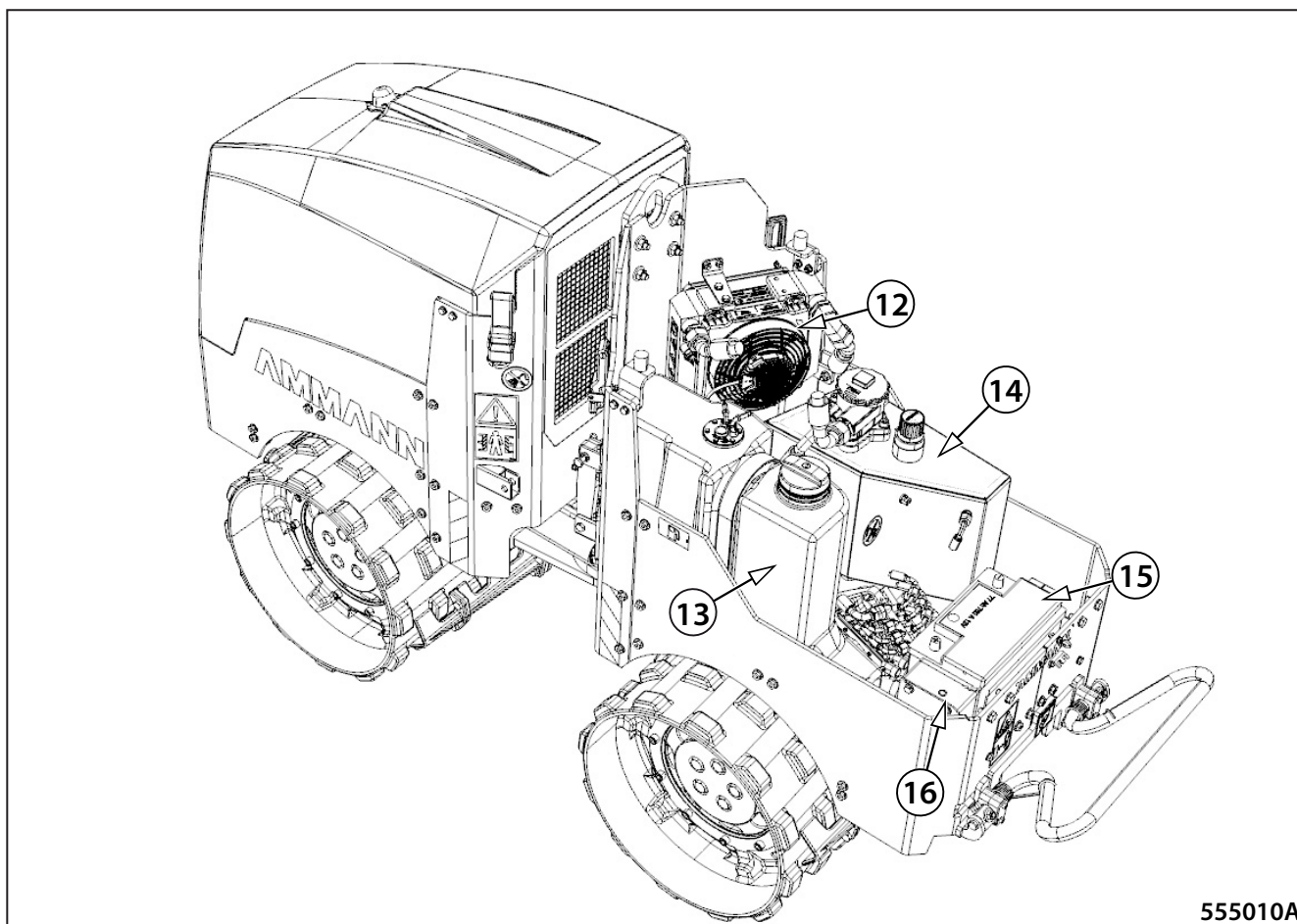

- 12 - Oil cooler
- 13 - Fuel tank
- 14 - Hydraulic tank
- 15 - Battery
- 16 - Controller (machine controller)

2.1. Major Safety Precautions

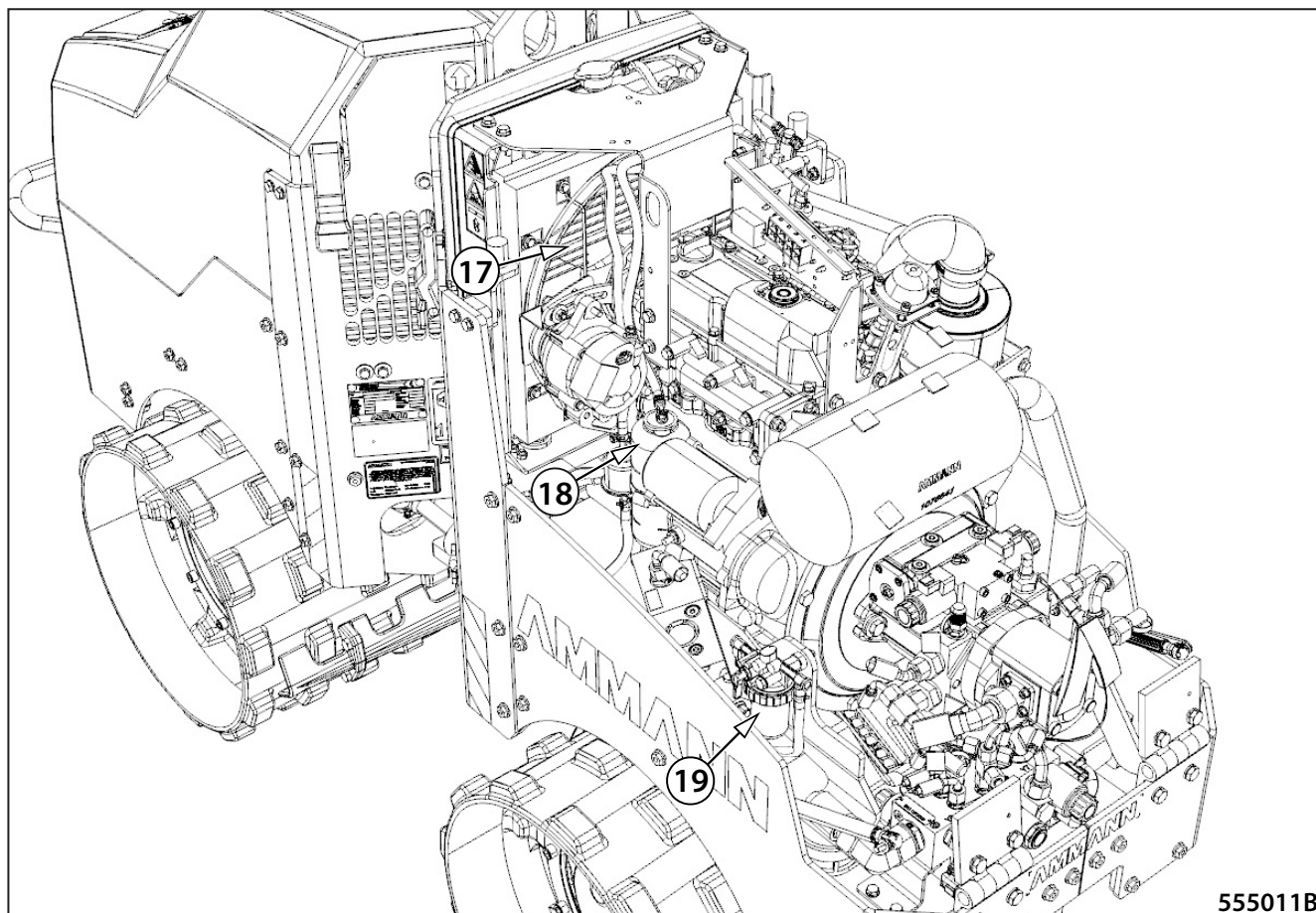

- 17 - Engine cooler
- 18 - Coolant expansion tank
- 19 - Water separator

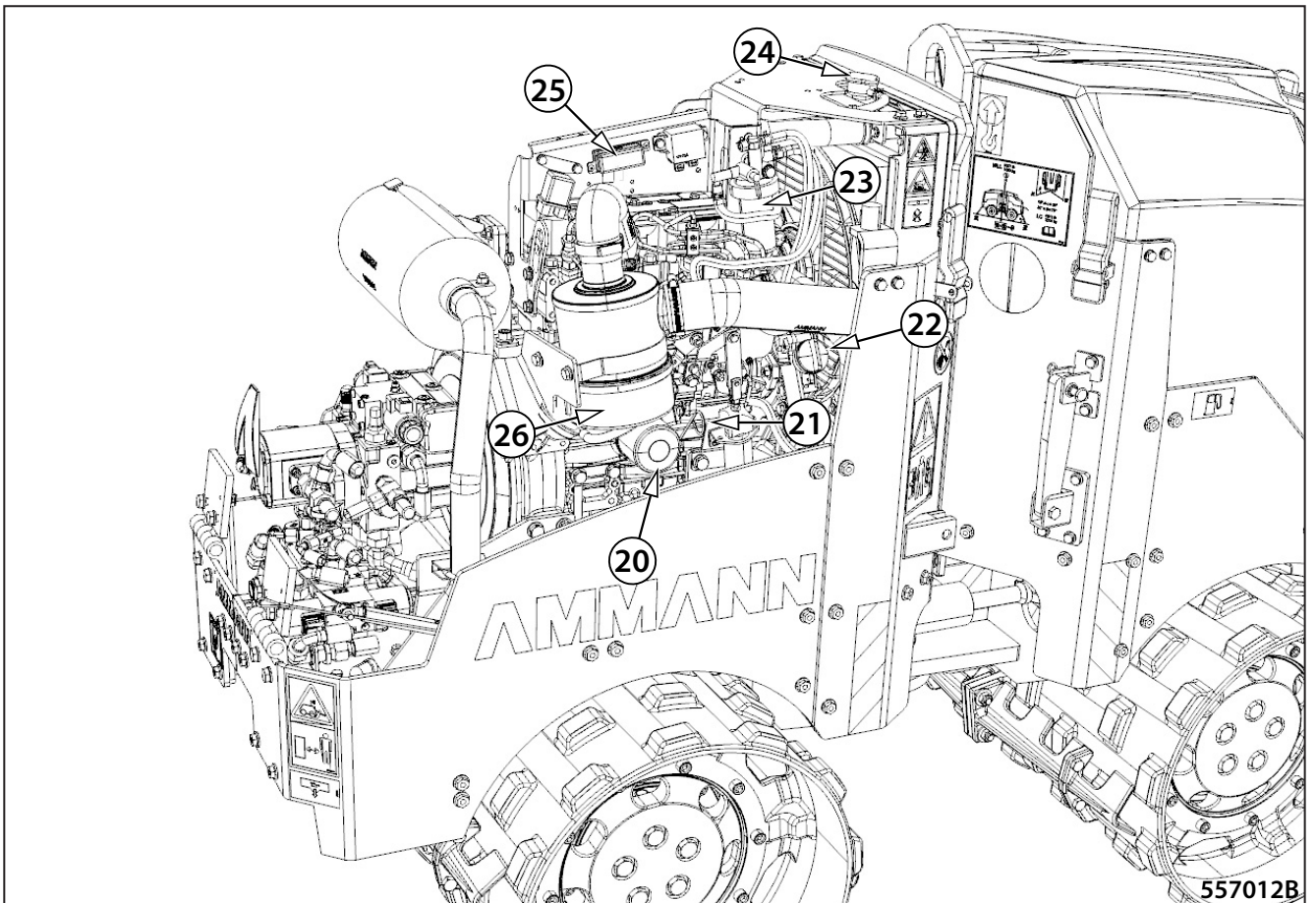

- 20 - Oil filter
- 21 - Oil gauge
- 22 - Oil filling port
- 23 - Fuel filter
- 24 - Coolant filling port
- 25 - Engine fuses
- 26 - Air filter

2.6. Actuators and dashboard instruments

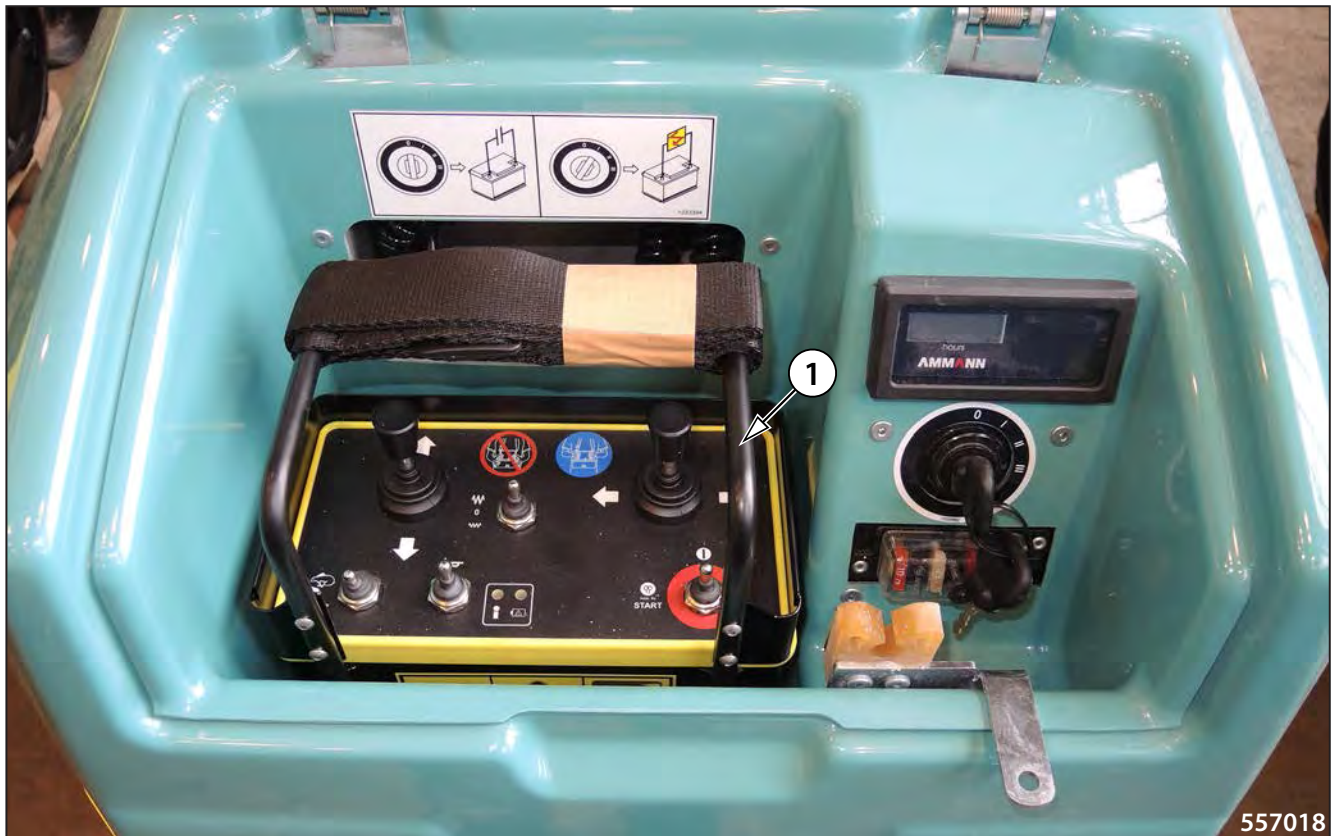

- 1 - Infrared remote control
- 2 - Storage area for spiral cable
- 3 - Display unit
- 4 - Ignition box
- 5 - Fuses

2.6.1. Display unit

Operating hours counter (1)



Control lamp for battery charge level (charge control) (2)

The pilot lamp lights up after the key in the switch box is switched in position „I“ and goes out after the engine starts. If the pilot lamp lights up during operation or does not go off after starting, carry out the following check immediately.

- Stop the engine.
- Check the engine for defective or loose V-belt.

If the battery charging lamp is still on after you have carried out this check, contact Ammann authorized service.



Control lamp functions (3)

The Error control lamp lights as soon as the controller recognizes an error.

The tilt sensor is activated. The compactor is in position with the angle exceeding 45°. Put the machine into vertical position.

Electric installation fault. Check the electric installation for short circuit or broken cable.

If the fault lamp is still on after you have carried out this check, contact Ammann authorized service.

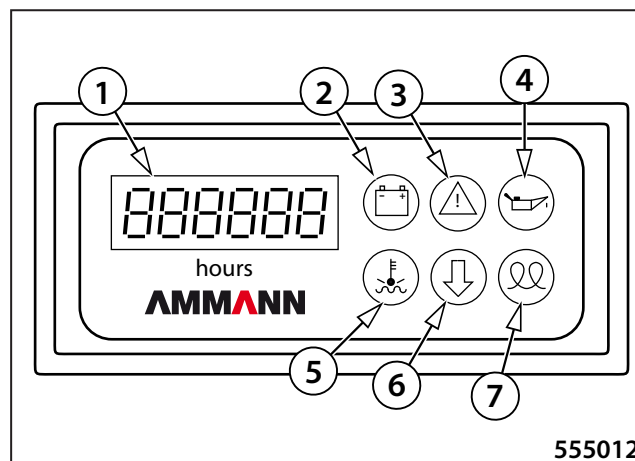

2.6. Actuators and dashboard instruments



Control lamp for engine oil pressure (4)

The pilot lamp lights up after the key in the switch box is switched in position „I“ and goes out after the engine starts.



If the engine oil pressure control lamp lights up during operation or does not go off after starting, stop the machine and turn off the engine immediately!

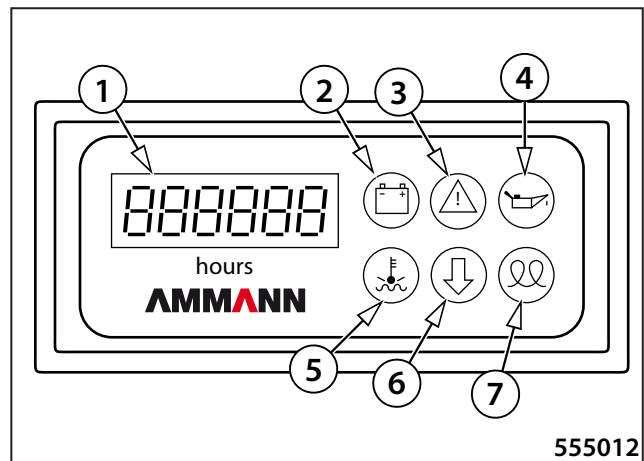

- Check the engine for oil loss and correct oil level.
- If the level of oil is correct, contact Ammann authorized service.

Note:

The machine is equipped with an automatic shutdown system. If the oil pressure falls below the limit value, the oil pressure warning lamp lights up. After the warning lamp has been lit for 4 seconds, the machine is shut down.



Control lamp for cooling water temperature (5)



Danger of engine overheating. Stop immediately!

If the coolant temperature control lamp lights up during operation of the machine, switch off the engine immediately and top up coolant!

- Check the cooling system for leaks and the radiator/expansion vessel for correct coolant level.
- You have not found a fault: Contact Ammann authorized service.

Note:

The machine is equipped with an automatic shutdown system. If the cooling water temperature exceeds the limit value, the temperature warning lamp lights up. After the warning lamp has been lit for 4 seconds, the machine is shut down.



Control lamp for shutdown bar (6)

The shutdown bar indicator lamp remains lit as long as the shutdown bar is actuated (OPTION).

The safety bar indicator also lights up during the activation of the near and remote halt.



Control lamp for pre-heating (7)

The pre-heating time lasts about 6 s. The pre-heating indicator lamp extinguishes when the engine is started.

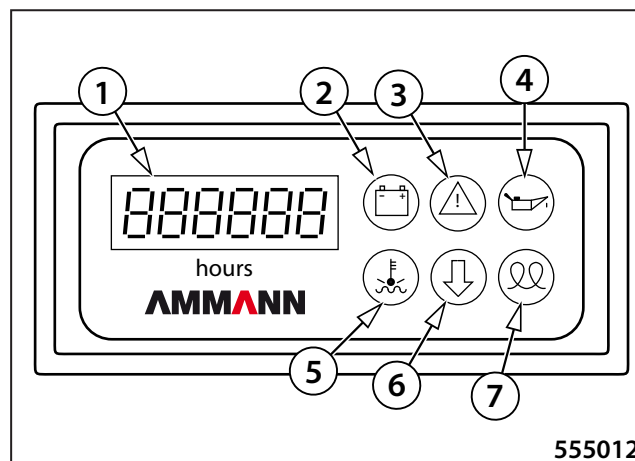

555012

2.6. Actuators and dashboard instruments

Cockpit fuses

The fuses are located under the cowling in the cockpit

1	F11	10 A	Controller, power supply
2	F12	25 A	Controller, outputs
3	F13	10 A	Display unit, shutdown bar
4	F14	25 A	Hydraulic oil cooler

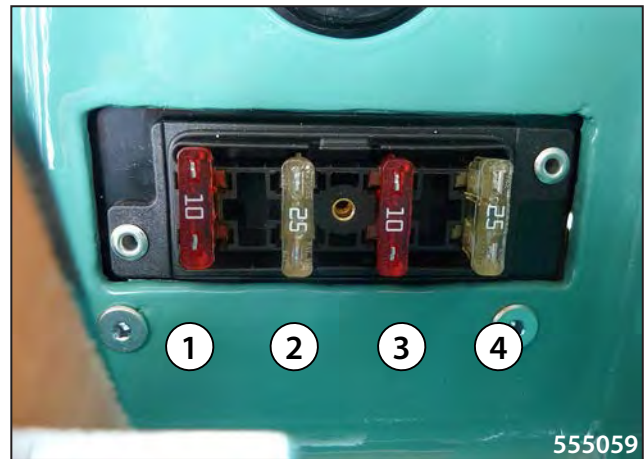

Engine compartment fuses

The fuses are located above the diesel engine.

1	F21	40 A	Pull-in solenoid
2	F22	10 A	Diesel pump, alternator
3	F23	40 A	Operating speed
4	F24	40 A	Pre-heating coil

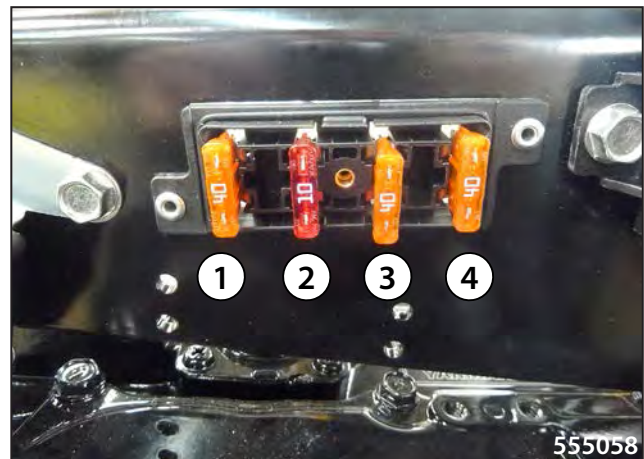

Replace fuses only with fuses of identical value!!!

2.6.2. Infrared remote control

- 1 - Operating speed (turtle) / travelling speed (rabbit).
- 2 - Forward drive / reverse drive
- 3 - High / low amplitude of vibrations



Do not use the vibration feature on steep slopes or under high angle of inclination.

Do not vibrate in buildings and on unstable ground.



Risk of lethal injury due to slipping or falling of the compactor.

- 4 - Left/right lock angle

- 5 - Start/Stop

Serves to start the engine. More in chapter 2.7.3. Engine start.



After the operation of the machine, all control sticks must be in the Stop position.



- 6 - LED signals

- 7 - Horn switch

2.6. Actuators and dashboard instruments



Replace any damaged rubbers protecting the control elements of the infrared remote control to prevent damage of the internal electronics caused by dirt or humidity.

When the protective valve is damaged, contact your dealer immediately to prevent damage of the internal electronics due to dirt or humidity.

Damaged solar cells of the infrared remote control must be replaced. The battery of the transmitter is not recharging without solar cells. In such case, the battery can only be recharged via a cable.



2.6.2.1. LED signals

- There are two LED signals on the transmitter: green and red.

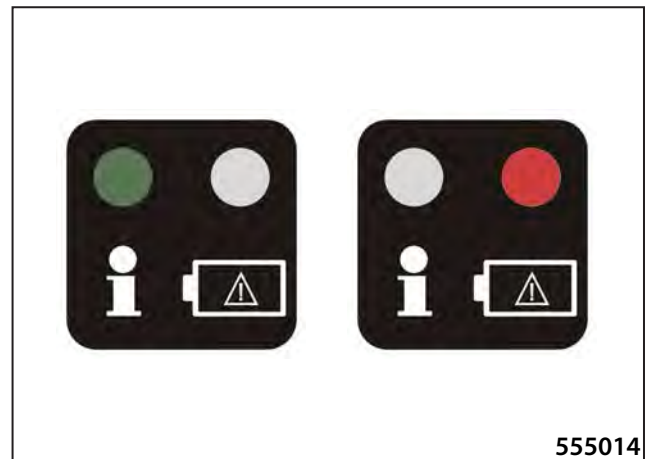

There are two LEDs on the cover: a green one and a red one.

Standard display (green)

Display	Cause
The green LED is blinking slowly.	The machine is controlled by the infrared remote control and cable
The green LED is flashing.	The machine is controlled by the infrared remote control

Battery charge status indicator (red).

The red LED indicator flashes faster or slower depending on the battery charge status.

The more the battery is discharged, the slower the red LED indicator flashes.

When the battery is discharged, the red LED indicator lights continuously.

Controlling via the infrared remote control

Display	Cause	Remedy
Red LED signal flashing.	Battery almost flat.	Connect the charging cable for at least 1 h.
Red LED signal lit.	Battery flat, remote control out of operation.	Connect the charging cable for at least 1 h.

Controlling via the infrared remote control and cable

Display	Cause	Remedy
The red LED flashes.	The battery is being charged.	
The red LED is lit.	The battery is fully charged.	

Note:

When the battery is discharged, it is still possible to control the machine using the infrared remote control and cable.

Battery warnings and errors are only displayed during active control (i.e., when a control element is actuated).

When disconnecting the cable from the infrared remote control, the red LED indicator lights up for about 1 second.

2.6. Actuators and dashboard instruments

Charging the accumulator of the infrared remote control:

The infrared remote control can be recharged using solar cells.

When the infrared remote control is charged through a cable, turn the key in the ignition box to the "I" position.



If the infrared remote control is without light for a long time, it is necessary to charge it up fully every two months at least. Otherwise the accumulator can get damaged irreversibly.

2.6.2.2. Cable connection

Spiral cable connector

- 1 - Spiral cable connector / protective cover fastener
- 2 - Solar cells / Transmission elements

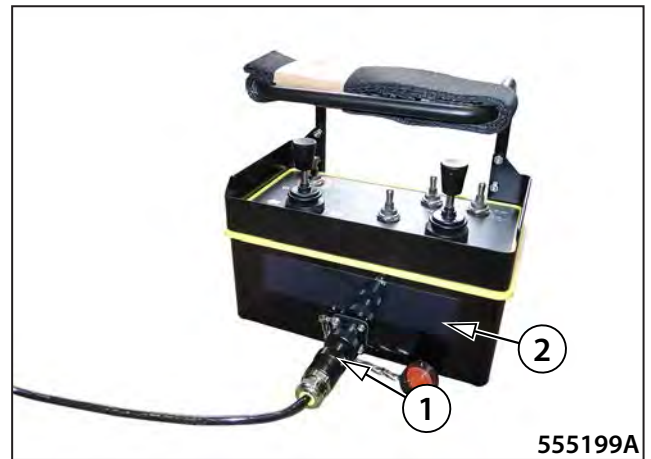

Automatic pairing function

- If you wish to control the machine via the infrared remote control, you must first perform a mutual assignment of addresses. This is only necessary when registering a new infrared remote control to the machine.
- Connect the cable to the transmitter.
- Turn the ignition key to the „I“ position.
- You can disconnect the cable after ca 3 seconds.
- The cable is not needed for operation with infrared transmitter.

Display	Cause
The green and red LEDs are blinking in unison quickly.	The infrared remote control is paired with the control unit of the machine.

Note:

This procedure normally only takes a maximum of about 3 seconds. If this blinking lasts longer or should even become permanent, there is a problem with pairing:

- A cable break in one of the signal lines
- A short circuit in one of the signal lines

2.6. Actuators and dashboard instruments

2.6.2.3. Handling

The infrared remote control is located under the control panel cover.

It includes the following transmission features:

- The solar cells
- The infrared diodes for data transmission and measuring the safety distance.

Before startup, clean the transmission elements.

Keep the solar cells clean during operation.



Accident hazard due to covered over lower part of the housing!

Before and during the operation with the infrared remote control, make sure the entire bottom part of the cover remains completely open throughout the whole operation.

In particular, the operator's hand must not cover the lower part of the housing even partially.

Proper carrying and use of the infrared remote control

Pay attention to correct positioning.

- Proper function requires direct visual contact between the manual infrared remote control and the infrared sensor on the machine.



The infrared sensor must always be in the area of effect of the infrared remote control.

The operating angle of the infrared remote control is 40°.

Proper use of the infrared remote control

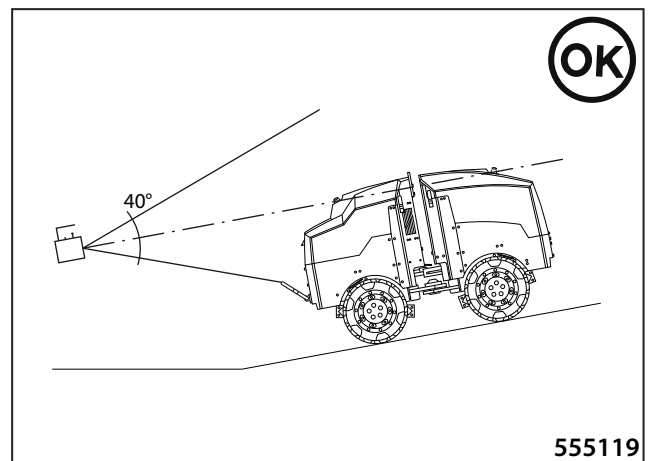
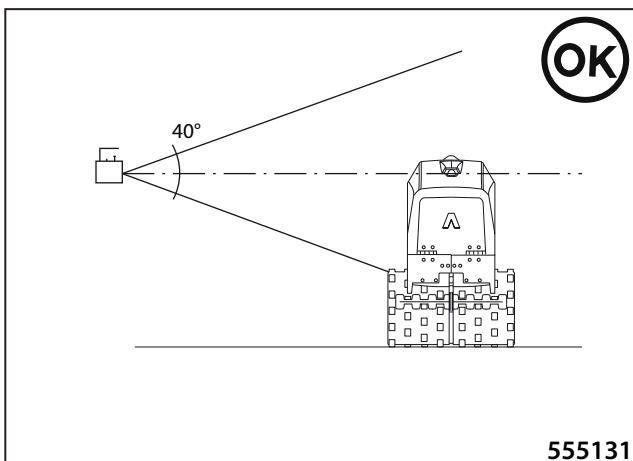
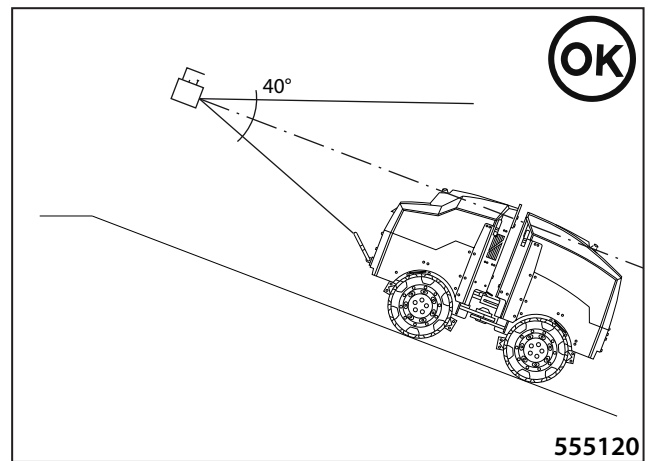
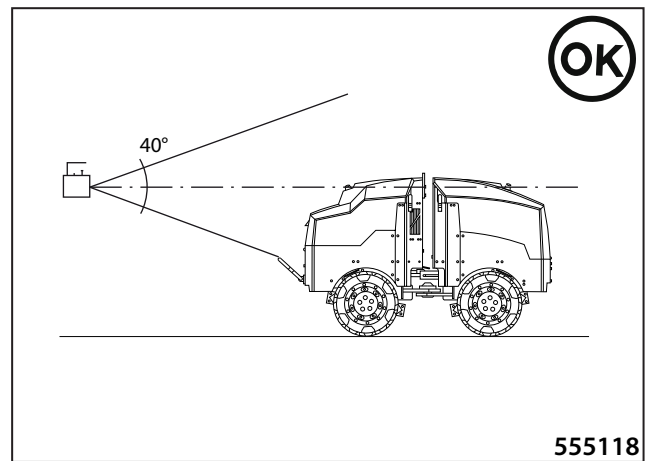
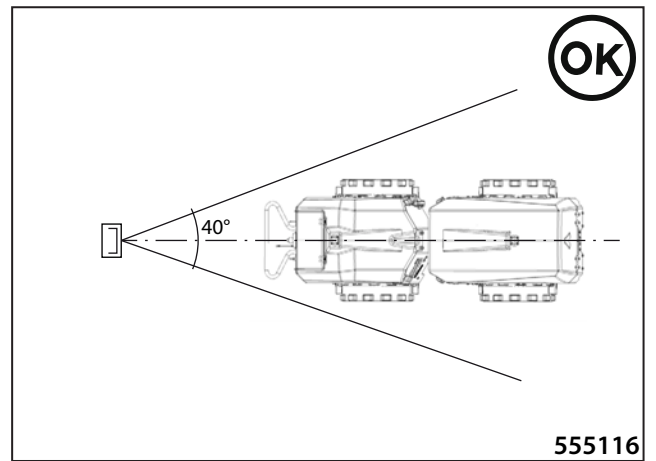

2.6. Actuators and dashboard instruments

Improper use of the infrared remote control



During the operation of the machine, it is forbidden to use the infrared remote control without direct visual contact between the infrared remote control and the infrared sensor on the machine.

The operating angle of the infrared remote control is 40°.

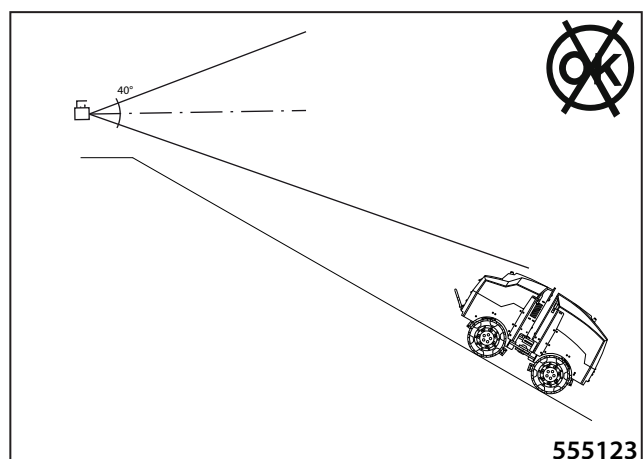
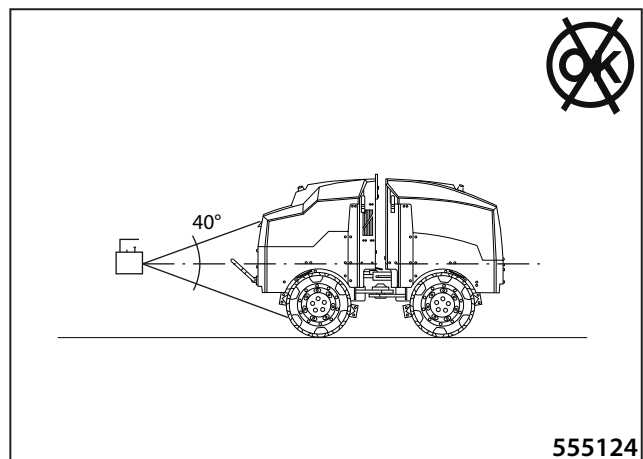
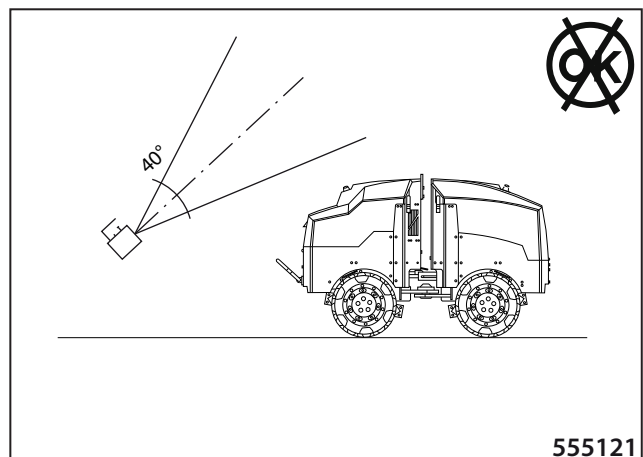
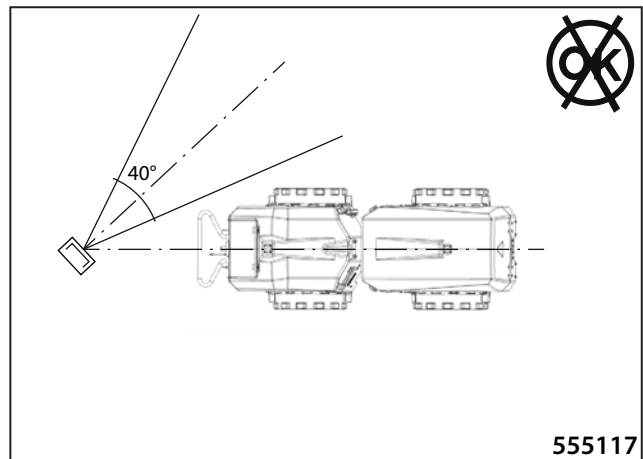

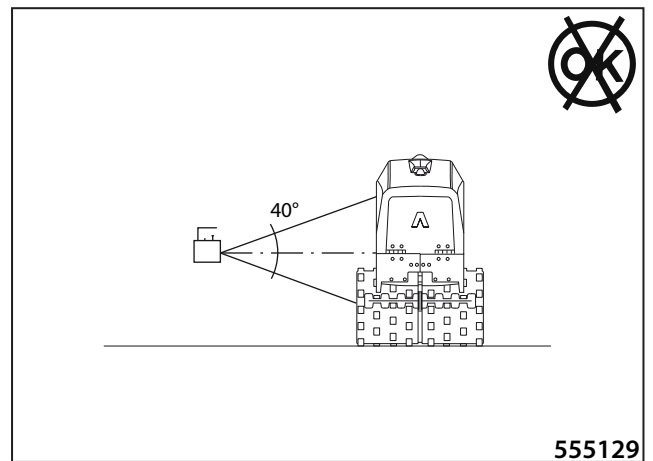
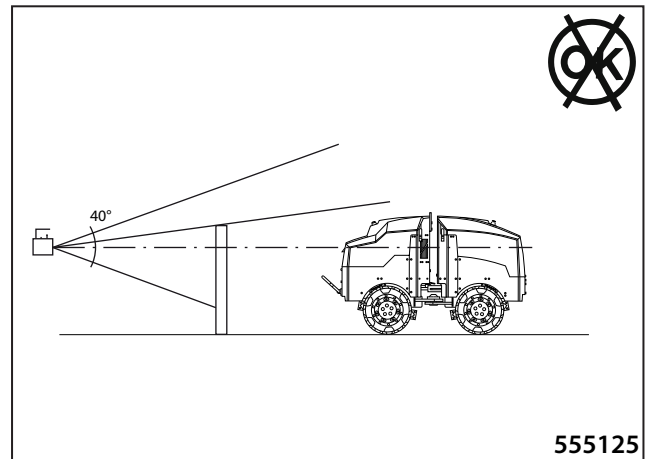
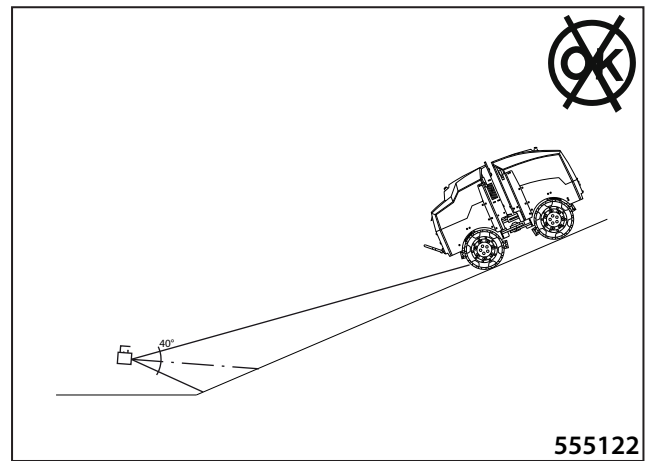

2.6. Actuators and dashboard instruments



During operation, aim the infrared remote control in the direction of the machine only. The cable connector (1) must face forward.

- The infrared remote control can lean on the operator's body.

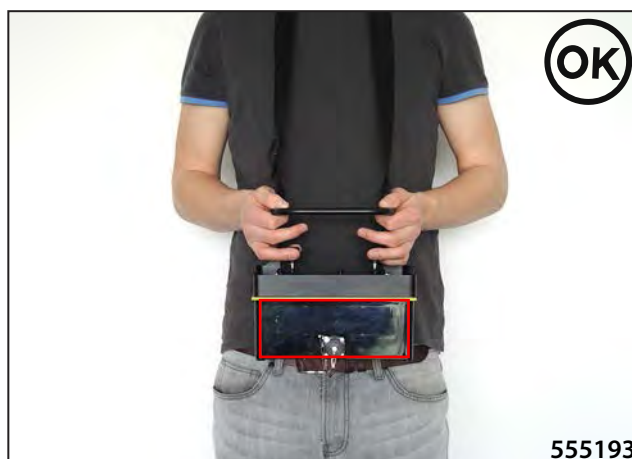

The side and front diodes of the infrared remote control must not be covered (e.g. by fingers, hand, foreign objects or dirt).





Do not aim the transmitter at reflective objects (large surfaces, light objects, other machinery, etc.).

Do not use the infrared remote control in the protected 2m zone or if there is insufficient visual contact between the machine and the operator or the infrared remote control, unless stated otherwise.

For optimum comfort, adjust the strap to the correct length.



555195



555196



The infrared remote control is provided with a protective cover. This cover reduces risk of inadvertent covering of the side and front diodes with hands or fingers of the operator. Do not remove the cover from the infrared remote control.



557022

2.6. Actuators and dashboard instruments

Protected zone and safe zone when using the infrared remote control

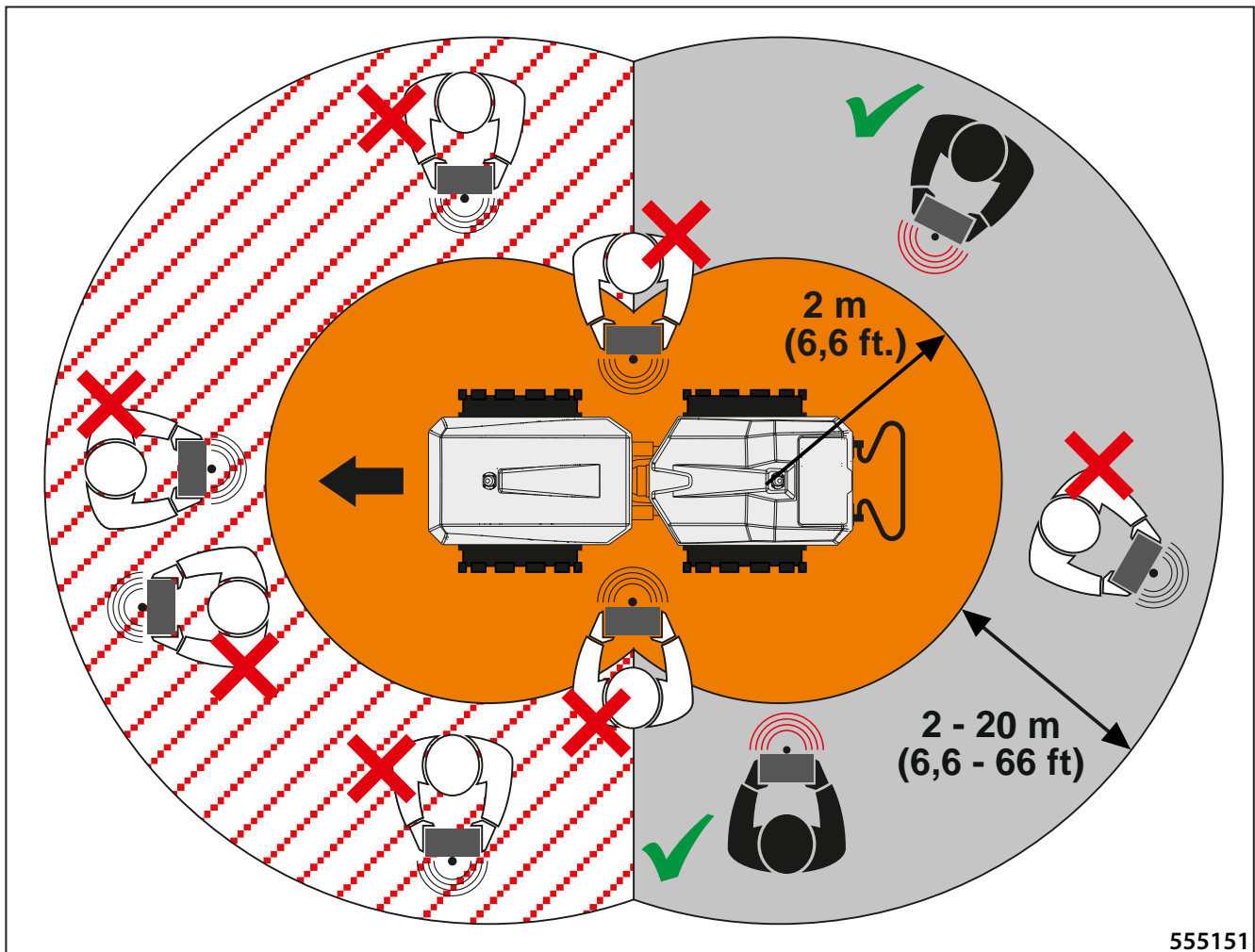

Protected, safe and operating zone during the operation of the infrared remote control and cable

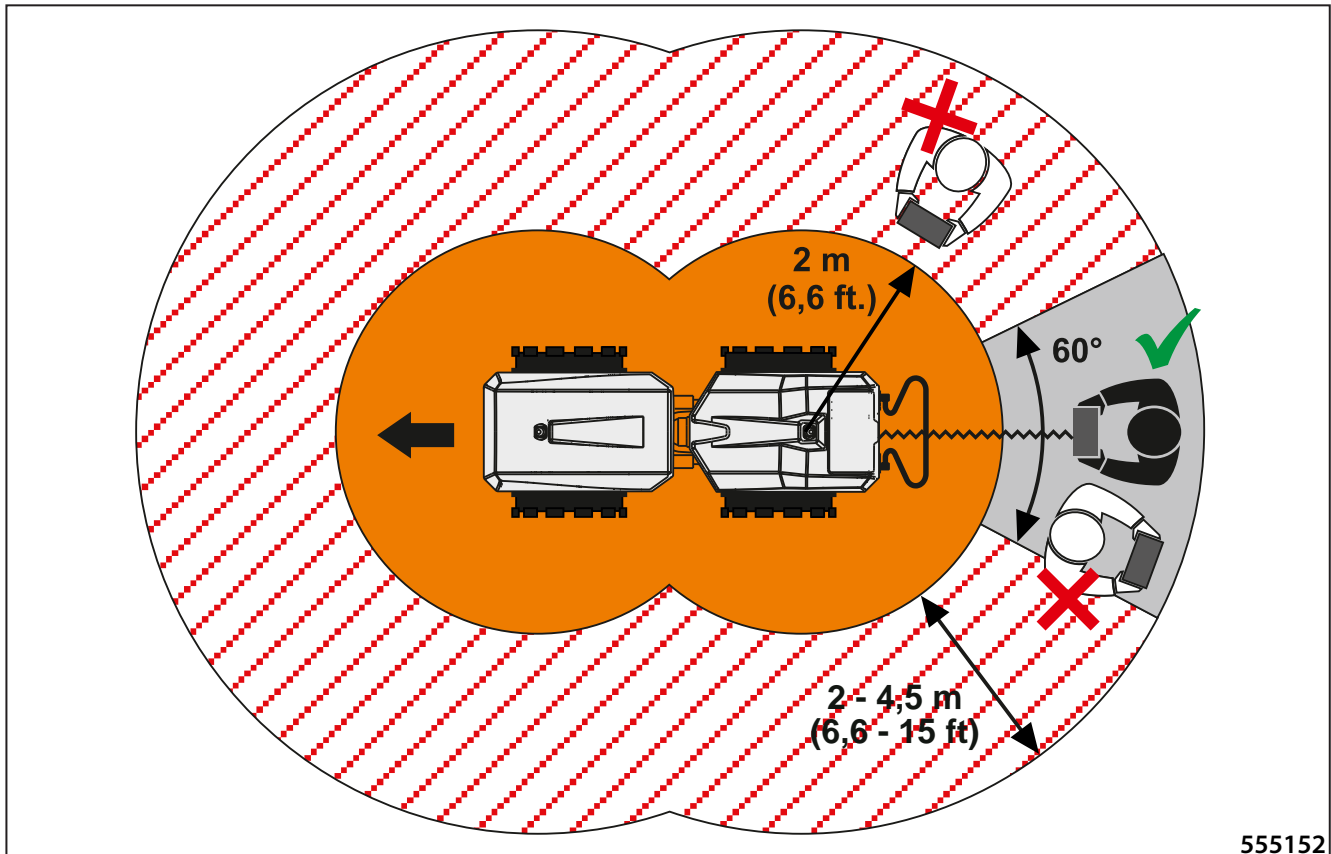

2.6.2.4. Near and remote machine halt

The near and remote machine halt function is an electronic safety feature designed to prevent the loss of visual contact between the operator and the machine and excessive proximity of the operator to the machine.

A machine equipped with infrared remote control contains sensors determining the safe distance of the operator from the working machine. This creates a protected zone and a safe zone.

The protected zone is within 2 m from the infrared sensors.

The infrared remote control is provided with a protective cover. This cover reduces risk of inadvertent covering of the side and front diodes with hands or fingers of the operator. Do not remove the cover from the infrared remote control.

The safe zone is an area marked in grey located at a distance of 2 ÷ 20 m when using the infrared remote control; see Fig. 555151.

When using the infrared remote control, the operator is allowed to move only within the safety zone.

The safe zone is an area marked in grey located at a distance of 2 ÷ 4.5 m when using the infrared remote control and cable; see Fig. 555152.

When using the infrared remote control and cable, the operator is allowed to move only within the safety zone.

Conditions for the near and remote machine halt function

	Infrared remote control and cable	Infrared remote control
Near halt	approx. 2 meters	approx. 2 meters
Remote halt	approx. 4,5 meters	approx. 20 meters

If the operator leaves the safe zone, the machine halts. The engine keeps running, but all other functions are disabled. In order to re-activate the machine, the operator must be located in the safe zone according to specific conditions, with the cable connected (2 ÷ 4.5 m) and when controlling via the infrared remote control (2 ÷ 20 m).



The infrared sensors do not react to people approaching the machine, only to the infrared remote control.

During the operation of the machine, do not enter the protected zone of two metres.

The border of the protected 2 m zone might be deformed by the deflection of rays of the infrared remote control or insufficient direct visual contact.

Do not use the infrared remote control in the protected 2 m zone or when there is insufficient visual contact between the machine and the operator or the infrared remote control, unless stated otherwise.

Operate the machine exclusively from the area in grey, i.e. from the safe zone. Outside the safe zone, the control switches of control elements do not correspond to directions of machine movements.

2.6. Actuators and dashboard instruments

2.6.3. Light indication

The warning light beacon is on the top side of the rear machine bonnet. The light indication of the machine is enabled when it is controlled with the infrared remote control.

It displays three various situations by flashing with a certain frequency.

Stand-by	0,3 Hz	The machine is not moving.
Drive	1 Hz	The machine is moving.
Warning	4 Hz	The machine operator is outside the safe zone. The machine will stop.



2.7. Machine control and use

2.7.1. Commissioning



Before putting the machine into operation, always read the operating manual and inspect the machine according to the instructions below.

Inspection of the machine before putting into operation:

- check, if the arm securing the joint during machine transport or loading is unlocked
- check the battery status of the infrared remote control
- check the automatic pairing function of the infrared remote control and the control unit
- check the workplace with regards to the prevention of interference of the electronic ballast (caused by external fixtures fitted with fluorescent tubes)
- check the near and remote machine halt function
- check the safety bar function (optional equipment)
- check the tightness of the fuel tank and fuel system
- check the tightness of the hydraulic circuit
- check the tightness of all screw connections

Note:

If the infrared remote control does not work and all LED indicators are off, connect the transmitter to the machine via the spiral cable. The battery will recharge.

2.7. Machine control and use

2.7.2. Protective cover

The protective cover protects the display unit and the infrared remote control from:

- weather conditions,
- vandalism,
- third-party actions.

Unauthorized access of third parties to the display unit and the infrared remote control can be prevented by the use of a pad-lock (not included in the machine equipment).



During operation, the cover must be closed so as not to obstruct the visual contact between the infrared remote control and the infrared sensor.



2.7.3. Start-up of the engine

Starting the engine using the ignition switch

0 Off

All electrical loads are off.

I Ignition on

All electrical consumers can be switched on.

II Pre-heating

III Start

Pre-heating

If the outside temperature is below 0°C:

Turn the ignition key to position II.

Hold it in this position for max. 6 sec.

Turn the ignition key further to position III.

Note:

The control lamps for engine oil pressure and charging light up when the ignition is switched on. They extinguish once the engine is running.

If the ignition key remains in the "I" position for more than four hours, the control unit switches off automatically. In order to start the engine again, it is necessary to return the key into the "0" position and then start the engine again.

Starting the engine using the infrared remote control

- Turn the ignition key clockwise to position I.
- Hold down the Start switch on the infrared remote control.
- Engine will start automatically after glowing.
- Release the switch.



2.7. Machine control and use

When using auxiliary starting source this power supply shall have starting voltage of 12 V.

How to start via starting cables from different machine

1. Connect one end (+) of cable pole to (+) pole of discharged battery.
2. Connect second end of (+) cable pole to (+) pole of the Machine battery from which starting will be made.
3. Connect one end of (-) pole to (-) pole of vehicle battery with the help of which starting will be made.
4. Connect second end of (-) cable pole to such part of the Machine being started which is wired in the engine (or eventually in the engine block itself).

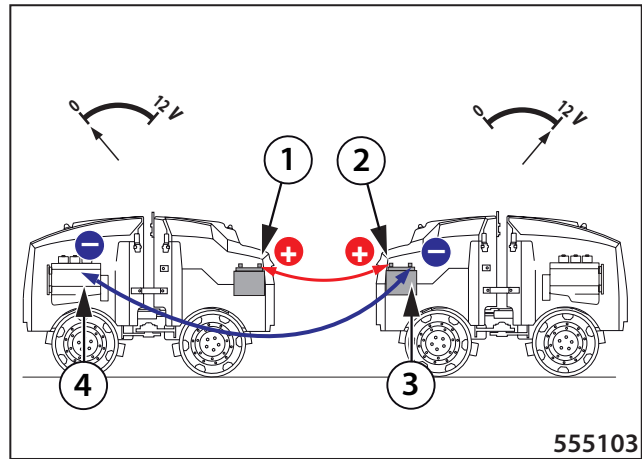

Observe unconditionally the sequence of operations given below!

Once started, disconnect the starting cables in reverse sequence.

When having used starting unit with no batteries connected do not disconnect this unit before Machine's battery is connected.



Do NOT connect cable of (-) pole to (-) pole of discharged battery of started Machine! Strong sparking followed by explosion of gas generated by the battery may occur when starting.

Non-insulated parts of starting cable collets may not touch each other!

Starting cable connected to battery (+) pole may not come into contact with electrically conductive parts of the Machine - short-circuit possible.

Do NOT bend over the battery - hazard of acid burn!

Eliminate presence of flammable sources (open fire, burning cigarettes, etc.).

Do NOT check presence of voltage in wires with the use of sparking via Machine frame!

2.7.4. Driving and braking

Overview of functions

	Infrared remote control and cable	Infrared remote control
Near halt	approx. 2 m	approx. 2 m
Remote halt	approx. 4.5 m	approx. 20 m
Function	Automatic pairing	
	Forward / backward drive function	
	Left / right steering function	
	Working speed / transport speed function	
	High / low amplitude vibration function	

After performing any function, the engine speed automatically increases to the working speed. If no function is activated within 15 seconds, the engine speed automatically drops to idle.



Driving forwards / backwards

Move the switch:

Toward the front: The machine moves forward.

Toward the rear: The machine moves backward.

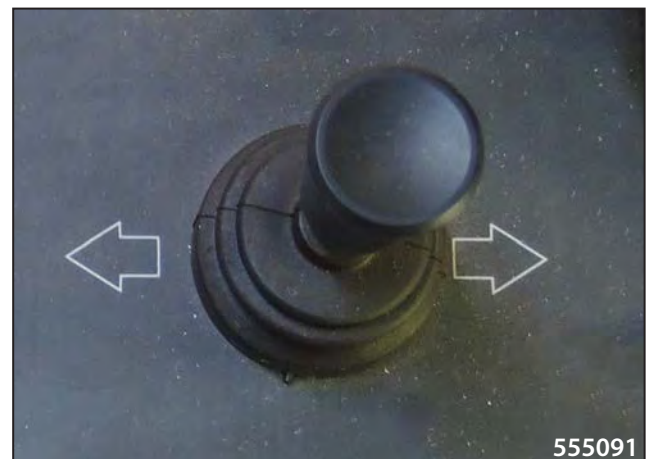

2.7. Machine control and use

Steering left / right

Move the switch:

Toward the left: the compactor turns left

Toward the right: the compactor turns right

Work gear / Transport gear

The machine is equipped with two gears.

Move the switch:

Toward the top (rabbit): the hydraulic system switches to the "transport gear" drive level. The machine drives at a high speed.

Toward the bottom (0): the hydraulic system switches to the "working gear" drive level. The machine drives at a low speed.

Note:

When large / small vibration is switched on, it is only possible to drive in the working gear.

When the machine is cold, the difference between high speed and low speed is minimal.

High / low amplitude vibration function

Move the switch:

Toward the top: The machine vibrates with a large amplitude.

To the center: The machine does not vibrate.

Toward the bottom: The machine vibrates with a small amplitude.

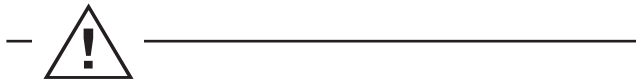
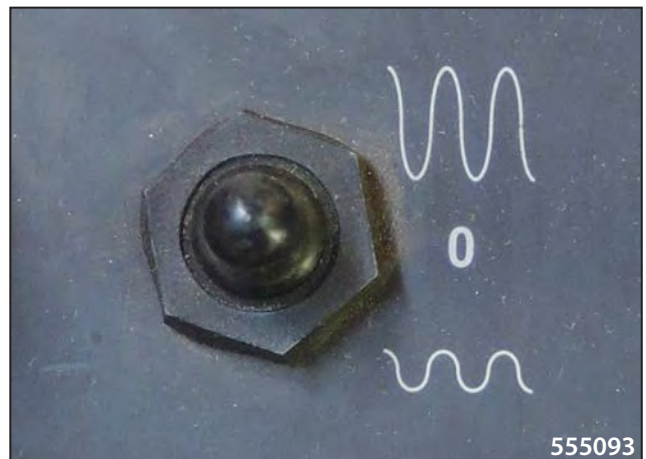

Do not use vibration on steep embankments or at steep angles!

Do not vibrate inside buildings and on unstable ground!

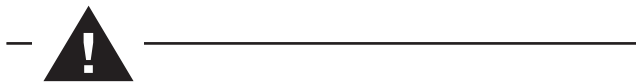

Danger to life through slipping or caving in of the machine!

Note:

Never use vibration while at a standstill! If the large / small vibration function is activated for more than 15 seconds while at a standstill, the machine controller shuts it off automatically.

When first started, it is only possible to use the small amplitude vibration function for the first 2 minutes.

Horn switch



557025



- **Only travel directly up or down slopes.**
- Do not drive across slopes.**
- Keep your distance to embankments and edges!**
- Do not drive at an angle into or out of the trench.**
- Park the machine on slopes only in such a way that it cannot overturn.**
- Use the machine on slopes only in such a way that it cannot overturn.**
- The machine drums have very poor adhesion on snow and ice. Driving or working on a slope in snow or ice is prohibited.**
- Damp and loose surfaces reduce the traction of the machine on upward and downward grades considerably. Adapt the speed of the machine to the terrain when driving on grades.**
- The nature of the ground and weather conditions can negatively affect the climbing ability of the machine.**
- Never drive on slopes that are steeper than the maximum climbing ability of the machine.**

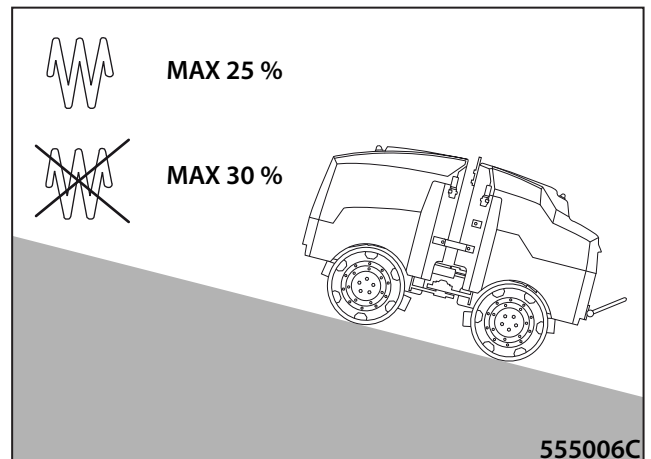

555006C

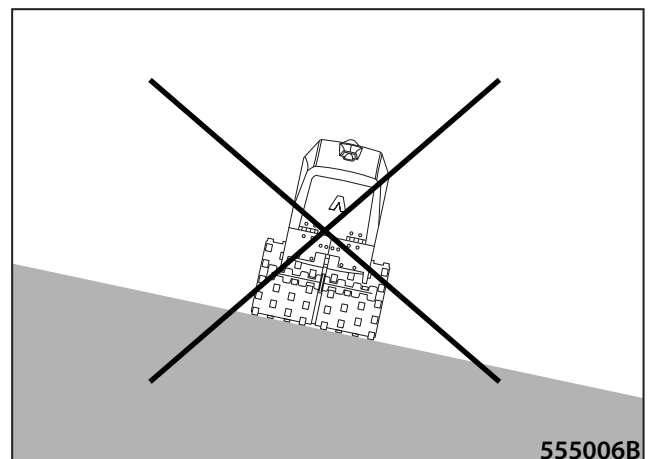

555006B

2.7. Machine control and use

2.7.5. Turning off the engine

- Move the switch on the infrared remote control to the Stop position.



- Turn the ignition key to the "0" position.



As long as the "Start-Stop" rocker switch is placed in the "neutral" position, the transmitter remains operational.

Always switch off the transmitter during work breaks and after completing work by moving the rocker switch to the "Stop" position.



2.7.6. Machine parking

- Clean the Machine to get rid of any coarse dirt.
- Carry out overall inspection of the Machine and repair any defects that occurred during operation.
- Use scotch blocks to secure the drums.
- Close and lock the protective cover.



Shut down the Machine on flat and paved surface. Confirm there is no potential of natural hazard (landslide, potential flooding due to any deluges, etc.) at the location.

2.7.7. Opening the front and rear bonnets



Danger of severe injury through loose clothing being caught and drawn in!

Only open the bonnet when the engine is off.

If trouble shooting makes working on moving parts of engine unavoidable, never wear: Necklaces, bracelets, rings, scarves, ties or other loose items of clothing.

If any of these get caught in moving parts there is a danger of serious injury!

Danger of scalding from hot water / steam!

Only work on a cool engine.

Keep enough distance to the exhaust.

There is one locking device each on the front and back as well as the left and right of the machine.

- Open both catches, on the right and the left.
- Push gently to lift the bonnet.

Note:

Two gas struts reduce the force required to open the hood and give it its final position. If you need to exert a greater force to lift the engine bonnet, replace the gas springs. Refer to chap. 3.6.22. Replacement of gas springs.



2.7. Machine control and use

2.7.8. ACEecon system

Informs the operator of the condition of the surface compacted by the machine. There is a sensor in the rear drum measuring the degree of compaction. The information about the achieved degree of compaction is displayed by LEDs. The more LEDs are on, the more the surface is compacted. The system is enabled when the vibration function is started.

If the machine passes repeatedly and more LEDs do not light up, the surface is compacted to maximum. The surface can be compacted to maximum before the maximum number of LEDs lights up. There is no increase at a surface that cannot be compacted (e.g. wet clay) even on the LED panel.

LED panel

The LED panels will flash shortly in violet when you turn the key in the ignition box. After the machine start-up, both of the panels will go off until the machine starts vibrating.

- If the LED panels start flashing in violet during operation of the machine or do not go off after the machine start-up, there is a fault. Check cable connections from the sensor to the LED panels.
- The degree of surface compaction is indicated by a number of lighting LEDs. The LEDs light in green and they light up gradually with the gradual compaction process.
- If the LEDs light in red, there is a vibration stroke. The surface is too stiff and the machine can get damaged if operated for a long time in such a condition. This condition can occur also when the machine passes a locally stiff surface, e.g. large stone under the surface.

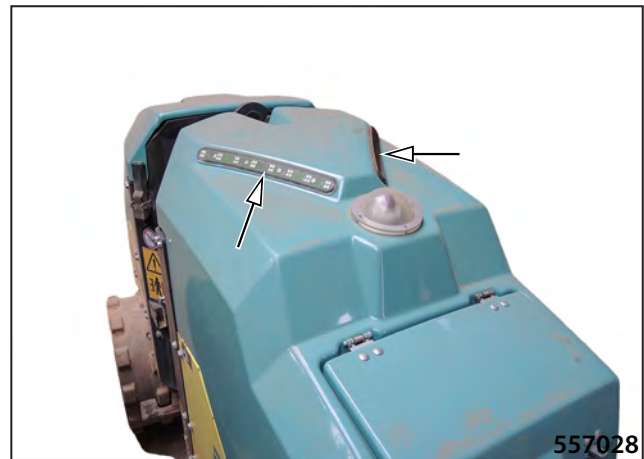

2.7.9. Roller overturning

In the event that the machine overturns, use a crane to put the machine back on its drums as soon as possible.

Turn the key to the 0 position, turn it off.



Under no circumstances should you try to restart the engine right away.

Prevent oil shock.

It can cause serious engine damage.



Operating fluids pose a risk to the environment!

Do not allow any liquids into drains, soil or the surrounding environment.

Immediately prevent the spread of any liquids leaking out, e.g. oil, diesel, antifreeze, battery acid.

2.7. Machine control and use

Damage check

Open the front and rear bonnet.

Disconnect the cable from the (-) terminal of the machine's battery.

Check the machine for any visible damage of individual parts of the machine.



**Focus especially on fluid leaks.
Empty all damaged containers.**

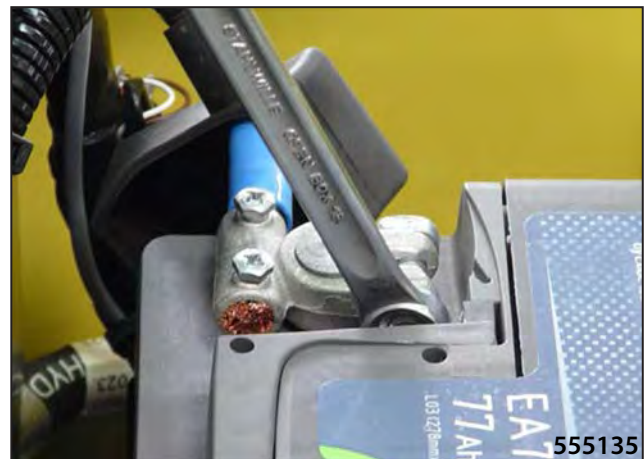

Prevention of oil shock



Before you start removing and disassembling any parts, thoroughly clean the area around the valve cover, engine cylinder heads and wiring holder.

If you do not find any visible damage or you have already repaired it, proceed as follows:

Remove the F21 fuse in the engine compartment (40 A).

Remove the air filter cartridges, replace if they are soiled with oil.

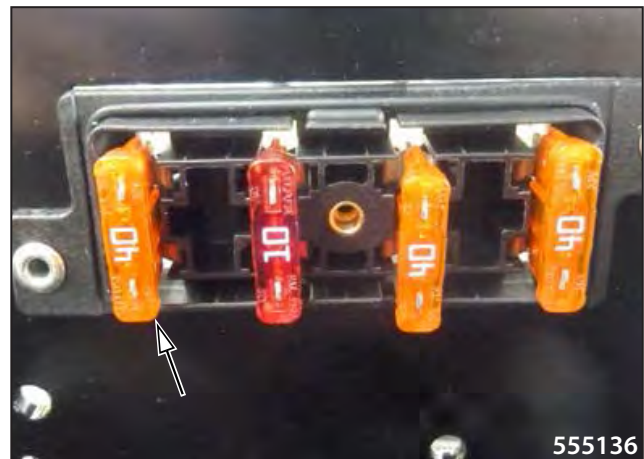

Clean the air filter inside if it is soiled with oil.



Remove the air filter hose and clean it if it is soiled with oil.



Remove the fuel filter.

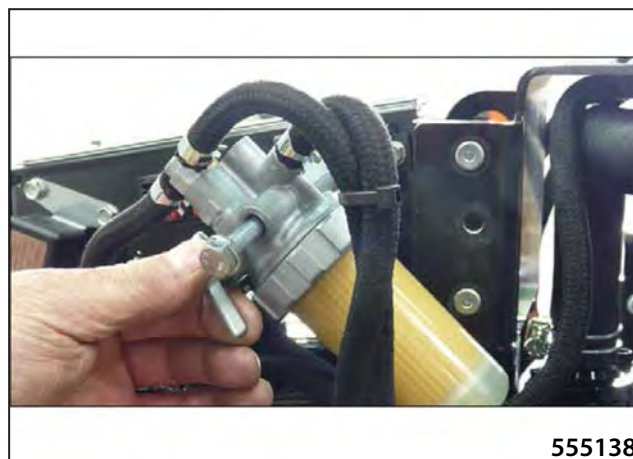

2.7. Machine control and use

Remove the wiring holder screws.
Do not damage the cable harnesses.

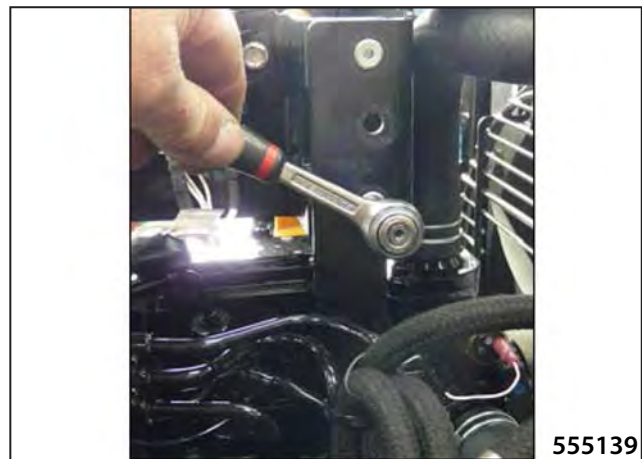

Remove the engine valve cover.



Disconnect the cables and contact connectors on the glow plugs.

Remove all three glow plugs.

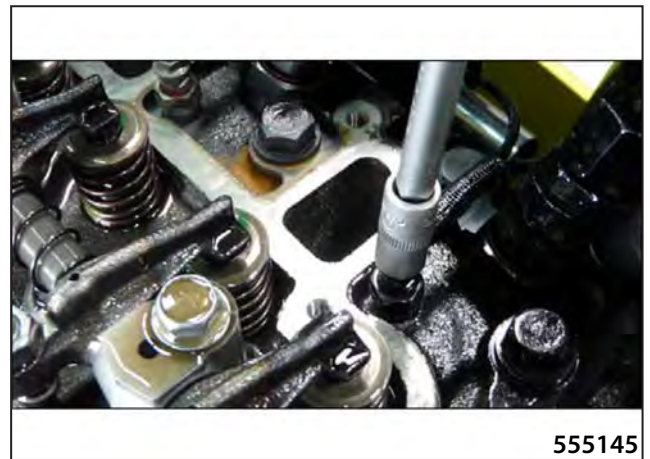

555145



555146

Turning of the crankshaft

Make sure that any accumulated oil was removed from the combustion chamber.

Rotate the engine twice using the centre screw on the crankshaft, use a ratchet spanner (1).

If the engine cannot be rotated, contact an authorized dealer.

Note

Danger of burning cable or short circuit.

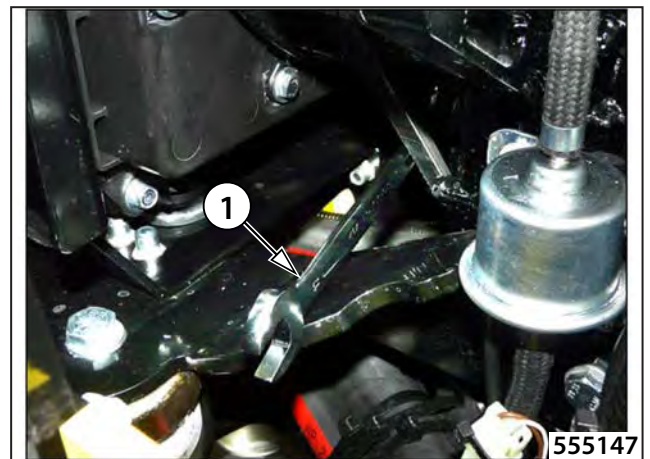

555147

Isolate the connecting cables from the glow plugs, e.g. using a piece of hose.



555148

2.7. Machine control and use

Reattach the wiring holder using two screws.

Reconnect the cable to the (-) terminal of the machine's battery.



Risk of burns from splashing oil!
Eye injuries, burns: Wear safety goggles.

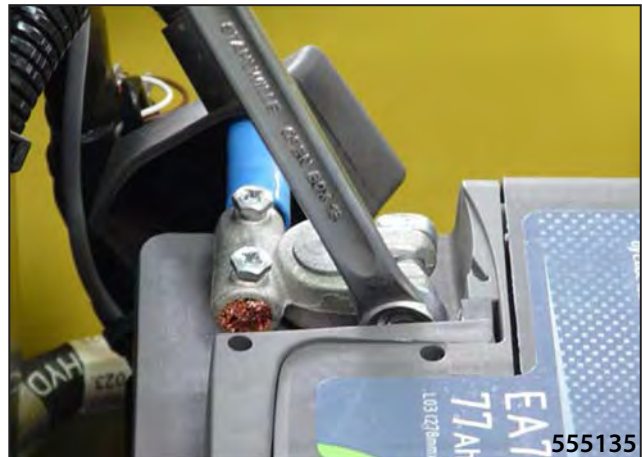

Rotating the engine using the starter

Rotate the engine using the starter, about 1–2 minutes.

After several revolutions, any oil accumulated in the combustion chambers should begin to flow out of the glow plug holes.

Repeat the procedure after about 5 minutes. There must not be any oil left in the combustion chambers.

Reattach the glow plugs (18Nm torque).



Reconnect the connecting cables and cables to the glow plugs (1.5 Nm torque).

Mount the engine valve cover.

Mount the wiring holder.

Rotate the engine twice using the centre screw on the crankshaft, use a ratchet spanner (1). If the engine cannot be rotated, recheck the assembly procedure, otherwise contact an authorized dealer.



Rotating the engine using the ignition switch

Turn the key in the ignition switch clockwise to the III position.

The engine must rotate.



Risk of burns from splashing oil!

Eye injuries, burns: Wear safety goggles.

If the engine does not rotate, stop the procedure and contact an authorized dealer.

If the engine rotates:

Check the levels of all fluids.

Refill if needed.

Reattach the F21 fuse into place.

Starting of the engine

First attempt to start:

Turn the key in the ignition switch clockwise to the III position.

The starting attempt was successful, the engine is running: Refer to section „**The engine is running**“.

The starting attempt was unsuccessful, the engine is not running: There might be air in the fuel system. Refer to section „**Checking the pump**“.

Checking the pump

Turn the ignition key clockwise to the I position.

Check if the electric fuel pump is working.

Let the pump run for about 1 minute. The system will automatically vent any air.

Second attempt to start:

Turn the ignition key clockwise to the III position.

Keep the engine running at idle speed.

Do not activate any function.

The engine is running

Keep the engine running at idle speed.

The engine will exhaust smoke until the oil accumulated in the exhaust system completely burns (this may take up to 1 hour).

Immediately visually check for any signs of fluid leakage.

If no problems were detected, set the engine to maximum speed, check the functions.



Risk of fire!

The exhaust pipe may shoot flames or glowing embers.

The amount of smoke coming out of the engine should gradually and noticeably decrease. If the amount of smoke coming out of the engine does not gradually decrease, the engine may be mechanically damaged.

Turn off the engine.

Check the levels of all fluids, refill if necessary.

Check fluid losses.

Start the engine.

2.8. How to transport the Machine

- The machine can move on its own between working sites.



When moving on the working site, observe the safety measures applicable to the working site.

When driving for long distances, 1-hour cooling breaks after 3 hours of driving should be taken. Failing that, you are exposed to the risk of damage to the machine for which the manufacturer is not responsible.

- When on the road, the machine should be transported on a vehicle.



When transporting the machine on a vehicle, observe the regulations in force in the given territory.

Make sure the transport carrier is braked and mechanically secured against undesired motion with scotch blocks (3) when loading or unloading.

When moving onto the transport carrier you must switch ON the function of Drum Slip Limitation. At the same time we recommend to put rubber bands or wooden planks, etc. underneath the drum.

The machine on the vehicle must be properly tied and mechanically secured against longitudinal and lateral displacement as well as against tipping (1). The drums must be secured using scotch blocks (2). The maximum force permitted for tying the machine to a transport vehicle is 2.5 t.

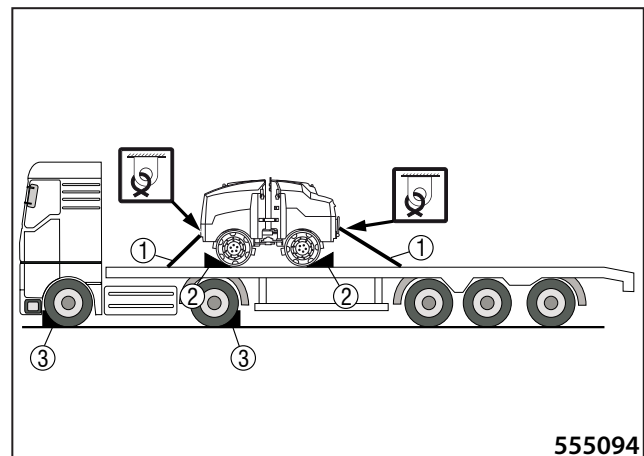

Center of gravity

The center of gravity relevant to transport is located 460 mm from the floor and approx. in the center of the machine, depending on the fill level of the diesel or water tanks.



2.8.1. Machine loading

- Use a loading ramp or crane to load the machine onto the transport vehicle.

2.8.1.1. Loading the machine using a ramp

- When loading the machine using a ramp, all safety regulations related to loading of the machine valid in the place of loading must be adhered to. The ramp must have appropriate loading capacity, antislip surface and must be stored on a flat surface. We recommend that you adhere to regulation BGR 233.
- Maximum permissible incline of the ramp is 30 %.



Non-adherence to the prescribed parameters of the ramp may result in damage to the machine.



Pay increased attention when loading the machine. Improper handling can cause serious injury or death.

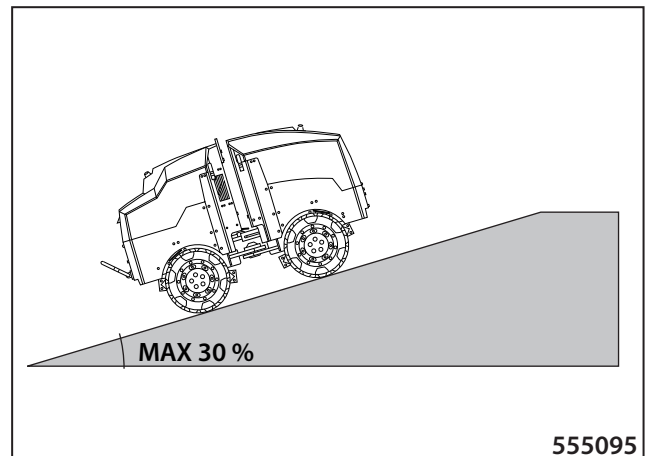

2.8. How to transport the Machine

2.8.1.2. Loading the machine using a crane

- When loading with crane the Machine is fitted with lifting lugs - refer to the Fig. showing the lifting method.
- The 1-point lifting eye is designed for a WLL of 1.6 tons (Working Load Limit).
- When lifting the Machine the Machine's joint shall be secured against turning.



Before lifting, make sure all screws on the 1-point lifting eye are damage free and securely tightened. There must not be any cracks or deformations on the one-point lifting eye.

When loading and unloading the machine, it is necessary to observe the provisions of ISO 12480-1 and to use slings under EN 1492-4+A1.



Pay increased attention when loading the machine. Improper handling can cause serious injury or death.

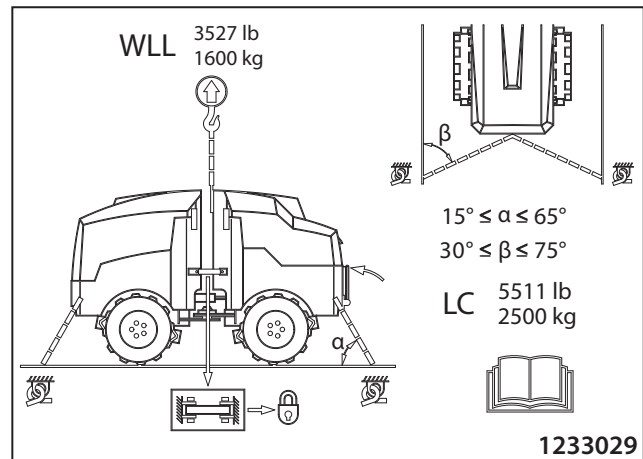

How to secure the joint:

- Release the lower part of the joint protection (1).
- First, remove the compression spring (2) and then the lock bolt (3).
- Carefully turn the machine steering until the joint protection comes in line with the opposite loop.
- Now steer to the left all the way to the stop.

Note:

In order to operate the steering, you must start the machine and maintain a distance of at least 2 meters.



Risk of crushing through presence in the pivoting area (danger zone)!

As soon as the machine is aligned, shut it off again.

- Hook the joint protection into place.
- Secure the joint protection with the lock bolt (3).
- Secure the lock bolt with the compression spring (2).



Do NOT enter the area under the lifted load!



Upon loading completion, please return the safety arm and crotters to their initial position.

Use corresponding, undamaged riggings of sufficient loading capacity.

To sling, please use only the lifting lugs on the Machine designed for that purpose.

Only a trained slinger may carry out the slinging.

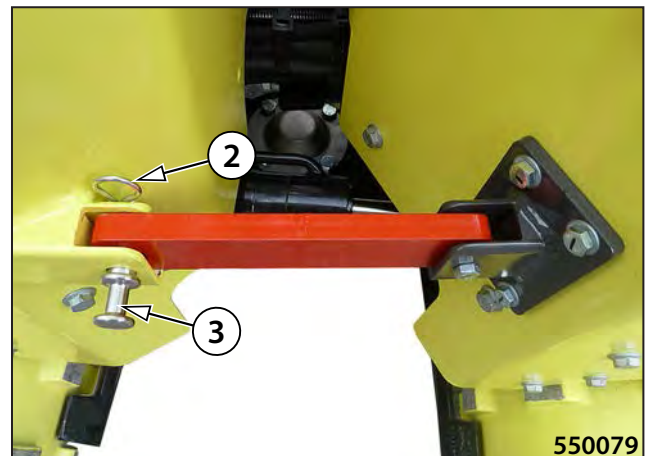
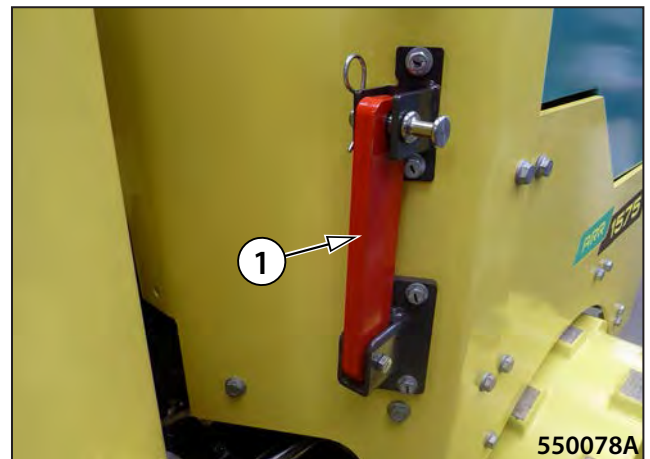

2.9. Special conditions of the Machine use

2.9.1. Machine operation during running-in

When putting a new machine into operation, the machine should not be run at full power for the first 50 hours (driving uphill with vibration).

2.9.2. Machine operation at low temperatures

Compacting in winter season depends on the content of fine particles and water in the soil being compacted. With the temperature declining below freezing point the soil becomes more solid and harder to compact.

It necessary to compact at the temperatures below 0 °C (32 °F) then it is possible to compact dry soil (and stony loose materials) or make swift compaction of non-frozen materials (before earth freezes through).

Preparation for work under low temperatures:

- Check concentration of the engine coolant.
- Exchange the engine oil with oil recommended for the range of outside temperatures.
- Use hydraulic oil of the corresponding cinematic viscosity.
- Use winter fuel.
- Check the batteries are recharged.

The good condition of the battery is a precondition for good starting under low temperatures. The machine can be used at full power only after the fillings have been heated up to their operating temperatures.



Min. temperature of engine coolant is 60 °C (140 °F). Max. temperature of 100 °C (212 °F).

At temperatures below -13 °C (9 °F), replace the oil in the hydraulic system with VG 32 class hydraulic oil.

Starting of the machine at temperatures below -23 °C (-9 °F) is not possible without preheating of the operating fluids.

2.9.3. Machine operation under high temperatures and humidity

- Engine power output decreases with increasing temperature and air humidity. Both power reducing factors are independent on each other:
 - a rise in temperature by every 10 °C (50 °F) results in a drop of power output by up to 4 % (at constant humidity)
 - a rise in relative humidity by every 10 % results in a drop of power output by up to 2 % (at constant temperature).

Note

The maximum permitted oil temperature for VG 46 class oil is 80 °C (144 °F); the maximum permitted oil temperature for VG 32 class oil is 70 °C (158 °F)

In the environment where hydraulic oil temperature remains constantly around 90 °C (194 °F), we recommend exchanging the hydraulic oil with oil which is one-class denser, with HV 68 cinematic viscosity.

2.9.4. Machine operation at higher altitudes

- In higher altitude, engine power output decreases as a result of lower atmospheric pressure and specific density of incoming air.
- The engine is equipped with an altitude sensor which adjusts fuel injection, eliminating the black smoke effect during operation of the machine at higher altitudes, in accordance with the EPA regulation.
- This function is activated automatically at the altitude of 800 m above sea level, and from this altitude up the engine output power is gradually reduced. For instance, at the altitude of 2000 m above sea level, the power output is reduced by 20 % of the maximum power output in regular conditions and the torque is reduced by 30 % (refer to the table).

Altitude (m above sea level)	0	1000	2000	3000
Power output reduction (%)	0	10	20	30
Max. torque reduction (%)	0	20	30	35



The engine power depends on the environment in which the machine is working.

2.9.5. Machine operation in very dusty environment

- When working in very dusty environment, please shorten the intervals of cleaning and replacing of the air filter elements and shorten the intervals of cleaning of the coolers.
- The recommended interval of cleaning is once a week.

2.9.6. Driving with vibrations on compacted and hard materials

When operating the Machine with vibration on hard materials (e.g. stony loose material), or with high level of compacting the base material, there can be even loss of contact between the drum and the material compacted (so called vibro-hit). This state will show in the increased vibration transfer into the Machine frame. Its partial elimination is possible via increasing the travel speed or changing the Machine vibration parameters (with the use of lower amplitude).



The driving with vibration on hard (frozen, concrete, overcompacted) surface or on bedrock is forbidden. There is a danger of damage to the machine.

2.10. Optional equipment

2.10.1. Shutdown bar

- The shutdown bar is located on the rear of the machine under the operating unit. A proximity switch is located on the rear section of the machine above the attachment point of the shutdown bar. If the machine moves against an obstacle with the shutdown bar, the shutdown bar is actuated and triggers the proximity switch. This sends a signal to the machine controller and the machine can now only be moved forward away from the obstacle. If the vibration function is running, it will be shut down. The vibration function must be restarted manually after the shutdown bar has been deactivated.
- During transport, the shutdown bar must be secured with a strap in the transport position.

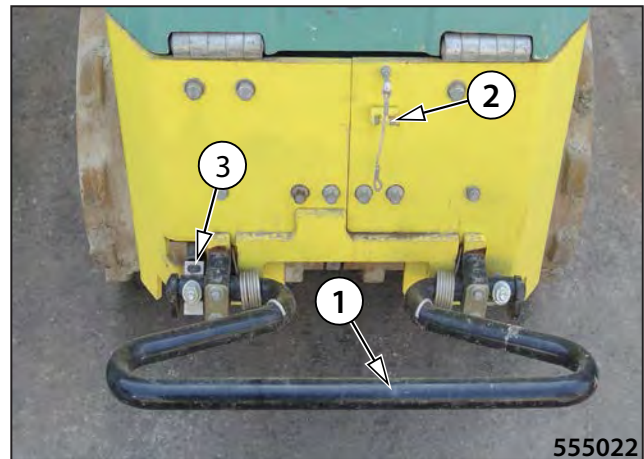

- 1 - Shutdown bar
- 2 - Point for securing the safety bar by a belt
- 3 - Proximity switch

Shutdown bar

Order number: 1241609

2.10.2. Drum extension set

- The drum extension set can be ordered for drum width of 640 mm. The extension increases the width of drums to 850 mm.



Drum extension set

Order number: 4-760100

2.10.3. Filter set 500 operating hours

- The filter set contains filters for regular maintenance after 500 operating hours.

Filter set 500 operating hours

Order number: 4-760099

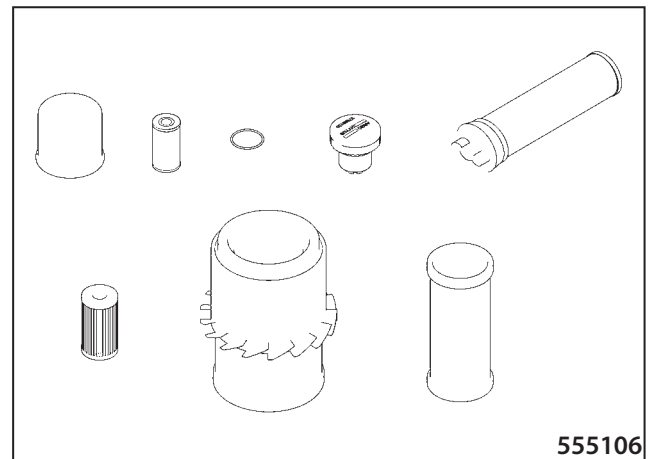

2.10.4. Cover tarpaulin

- The covering tarpaulin of rigid and waterproof material protects the machine against adverse climatic conditions, dust, dirt and vandalism. Four outside and inside use.

Cover tarpaulin

Order number: 3-51856



3. MAINTENANCE MANUAL

ARR 1575

(Yanmar Tier 4 Final)

3.1. Safety and other measures for machine maintenance

3.1.1. Safety of machine maintenance

Lubrication, maintenance and adjustment must be carried out:

- by professionally trained personnel
- according to safety instructions given in the Operation manual
- in terms stated in the table of lubrication and maintenance
- on the machine marked with "Machine in repair" tag
- on the machine standing on a flat solid surface and secured against motion (by scotch blocks), always with the engine off, the key removed from the ignition box and the wiring disconnected
- on cold machine parts
- after the machine, lubrication points and maintenance places have been cleaned
- with the use of suitable, undamaged tools
- with the use of original spare parts from the catalogue of spare parts
- at sufficient lighting of the entire machine in a case of poor visibility and at night
- in such a way that all removed covers and safety elements are reinstalled after the work is completed
- by retightening of all bolted connections – with the torque specified, and checking the connections for tightness
- with the use of recommended operating fluids stated in the operation manual.



After the adjustment or maintenance is completed, check proper function of all safety devices!

3.1.2. Fire protection measures during exchanges of operating fluids

- From the point of fire hazard, the flammable liquids used on the machine are divided into the following hazard classes:
 - class II - flammable substances with the point of ignition from 21 °C to 55 °C - diesel oil (according to specification from the supplier)
 - class III - flammable substances with the point of ignition from 55 °C to 100 °C - diesel oil (according to specification from the supplier)
 - class IV - flammable substances with the point of ignition from 100 °C to 250 °C - mineral oils, lubrication greases
- The place for carrying out an exchange of operating fluids must be situated in such a way that does not interfere with an explosion or fire hazard area.
- It must be identified with "No smoking" and "No open fire" signs and marks.
- The handling area must be dimensioned so that it can catch a volume of the flammable liquid equal to the capacity of the biggest vessel, transport container.
- The place for exchanging of operating fluids must be equipped with portable fire extinguishers.
- To handle operating fluids, use such vessels like metal barrels, canisters or sheet-metal cans.
- Transport containers must be properly closed during storage.
- The vessels must be only with one hole, be always stored with the opening up and secured so that their content cannot flow or drip out.
- The vessels must be identified with indelible inscription indicating the content and flammability class.

3.1. Safety and other measures for machine maintenance

3.1.3. Ecological and hygienic principles

When operating or maintaining the Machines the user shall be liable to follow the general principles of health and environment protection according to the laws, ordinances and regulations in individual territories of the Machine use.

Hygienic principles

- Crude oil products, cooling system media, battery media and coating compositions incl. thinners are materials harmful to health. Workers coming into contact with these products during machine operation or maintenance shall be liable to follow the general principles of their own health protection and conform to the safety and hygienic manuals of these products' manufacturers.

We call your attention to the following in particular:

- Eye protection and skin protection during work with the batteries
 - Skin protection during work with crude oil products, coating compositions or cooling liquids
 - Proper hand washing upon work completion and before any meal; use adequate reparation cream to treat your hands
 - Adherence to the instructions given in this Manual
-
- Always store the crude oil products, cooling system media and battery media, and coating compositions incl. organic thinners, and also the cleaners and preserving agents, in the genuine, original and properly labelled packages. Do not admit any storage of these materials in unlabelled bottles or in any other vessels with regard to the hazard of mistaken identification (faulty change).
 - When skin, mucosa, eyes are accidentally stained, or vapours inhaled, immediately apply the first aid principles. In the event of accidental use of these products get prompt medical attention.
 - When working with the Machine in cases where the Machine has platform fitted, cabin windows are left opened, always use ear protectors of adequate type and version.

Ecological principles



The media of Machine's individual systems, and some of its parts after having been discarded (dismantled, media exchanged) become waste with hazardous properties against the environment.

This category of waste products includes the following in particular

- Organic and synthetic lubricating materials, oils and fuels
- Cooling liquids
- Battery media and the batteries themselves
- Cleaners & preserving agents
- All dismantled filters and filter elements
- All used and discarded hydraulic or fuel hoses, rubber-metal and Machine's other elements, made dirty due to the abovementioned products.



The given materials and parts, when scrapped, shall be handled compliant to the respective national regulations on environmental protection, and in line with the health protection regulations, as well.

3.2.1. Engine oil



Engine oil is specified by its performance and viscosity classifications.

Performance classification according to

API (AMERICAN PETROLEUM INSTITUTE)

ACEA (ASSOCIATION DES CONSTRUCTEURS EUROPÉENS DE AUTOMOBILE)

Viscosity classification

To determine SAE (Society of Automotive Engineers) viscosity class, the ambient temperature and type of operation in place of usage of the machine are decisive.

Permitted oil according to API: CF

Permitted oil according to ACEA: E-3, E-4 a E-5

All season - SAE 15W-40 (e.g. Valvoline, Premium Blue,).

NOTE

Exceeding of the lower temperature limit does not damage the engine, it may only cause starting problems.

It is suitable to use general-purpose multi-grade oil in order that oil need not be exchanged because of ambient temperature changes.

Use of synthetic engine oils is permitted subject to the same performance and viscosity limitations of mineral (petroleum) based engine oils. The same oil change intervals must be applied to the synthetic oils that are applied to mineral (petroleum)based engine oils.

For easier start at temperatures below 0 °C (32 °F), SAE 10W-30 oil is recommended by the engine manufacturer.

°F °C

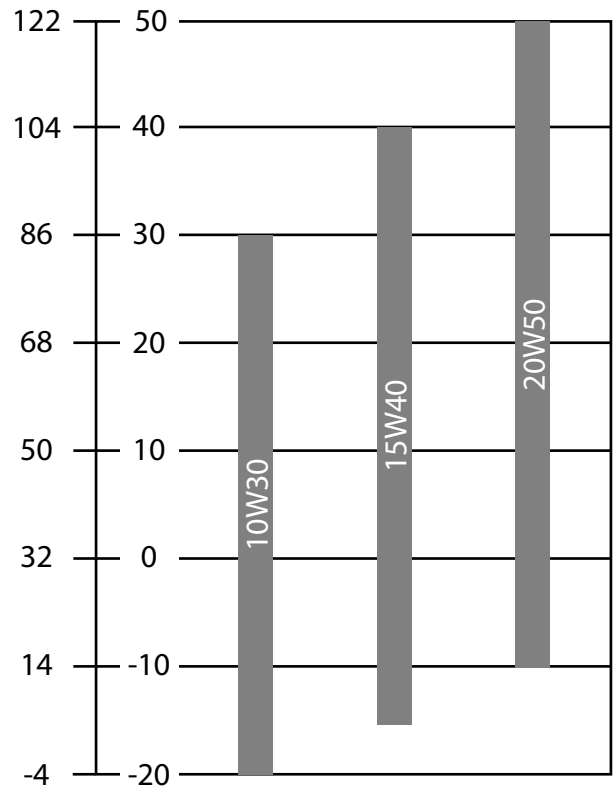

555072



Exceeding the upper temperature limit must not last for long, taking into consideration reduced lubricating properties of oil.

3.2. Specification of fluids

3.2.2. Fuel

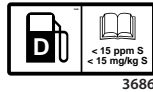

Diesel is used as fuel:

- CEN EN 590:96
- ASTM D 975-94: 1-D, 2-D
- ISO 8217 DMX

NOTE

Engine producer recommends to use fuel with sulphur content less than 0.05 weight percent.



Therefore use winter Diesel fuel at outdoor temperatures below 0 °C (32 °F).

Mixing diesel with special additives is prohibited.

Use of biofuel (Diesel fuel)

Using the fuel mixture under the trade name of Bionafta is in principle approved by the engine manufacturer for the engine on the machine if it conforms to the specifications under EN 14214 or ASTM D6751. Up to 5 % portion of biodiesel is accepted.

Before using Bionafta on the machine, make sure that it is supplied by a reputable supplier who supplies fuels corresponding to the above-mentioned standards.

Always ask the supplier of Bionafta for information concerning the condition under which it can be used.



Guarantee for the engine will be rejected when using Bionafta not conforming to the above-mentioned standards and if the fuel system or engine is damaged as a result of using improper Bionafta!

When using Bionafta, power can be reduced by up to 12% depending on the used mixture of Bionafta. Therefore, do not adjust the engine or the setting of the injection pump for increasing the power in any case. Never mix the fuel mixture at the place of use.

Bionafta has a higher cloud point at a low ambient temperature, which leads to the creation of wax crystals in the fuel resulting in the fuel filter clogging.

When using Bionafta, it is necessary to shorten the intervals of the engine oil exchange and replacement of an oil filter and fuel filter.

When changing over to Bionafta, the action of Bionafta releases corrosion and impurities created on the fuel tank internal walls. Impurities are brought by the fuel to the filter catching them and the filter must be replaced afterwards.

Bionafta has a higher ability to absorb atmospheric moisture, which results in the condensation of atmospheric moisture on the internal walls of the tank and a higher content of water in the fuel and the need for more frequent discharging of water from the fuel filter separators. The possibility of the occurrence of the problem increases in cold weather.

If Bionafta (Biodiesel) is used all the year round, it is necessary to clean the fuel system under the engine operation with a clean diesel fuel for at least 30 minutes before parking the machine for longer than 3 months. Further, it is necessary to drain off the fuel tank, clean it, and either fill it with diesel fuel or minimise the occurrence of moisture and limit the microbiological growth inside the tank. Consult the measures with the fuel supplier.

3.2.3. Coolant



Yanmar engines:

Coolant

The coolant specification must meet requirements of:

ASTM D6210

ASTM D4985

JIS K-2234

SAE J814C, J1941, J1034 or J2036



To fill the cooling circuit, use the coolant in the mixing ratio of 50 % / 50 % with high-quality water (thermal protection up to -37 °C).

Change the coolant every 2,000 hours, after 2 years at the latest.

Note:

The machines are filled with a cooling solution with the Bantleon Avia Antifreeze NG coolant, specification SAE J 1034 at the manufacturer's during the production.

It is a coolant based on monoethyleneglycol containing silicates. It does not contain phosphates, nitrates, amines and borates.

There is an Avia NG label placed at the point to fill the coolant into the machine.



Refill the cooling circuit with the same or a completely miscible coolant of the required specification.

If the use of a different, immiscible coolant is necessary, the cooling circuit must be completely drained and cleaned with clean water repeatedly, at least 3 times. However, it is not allowed to use a coolant of a different specification than stated by the engine manufacturer.

The coolant protects the cooling system from freezing, corrosion, cavitation, overheating, etc.

It is forbidden to operate the machine without coolant even for a short time.

It is forbidden to use a coolant of a different than prescribed specification and base. The engine and the cooling system can get damaged and the warranty lost.

Always check the ratio of antifreeze cooling agent in the coolant with a refractometer before the winter season starts.

Water quality

Do not use hard water with a higher content of calcium and magnesium, which brings calculus formation, and with a higher content of chlorides and sulphates, which causes corrosion.

The maximum content of compounds of calcium and magnesium is 170 milligrams – hardness of water.

The maximum content of compounds of chlorine is 40 milligrams.

The maximum content of compounds of sulphur is 100 milligrams.

Safety instructions:

- 1) **Protect your hands with protective gloves.**
- 2) **In case of ingestion immediately seek medical treatment.**
- 3) **In case of contact with skin or clothing immediately wash the affected area with clean water.**
- 4) **Do not mix different types of coolants. The mixture can cause a chemical reaction with formation of harmful substances.**

3.2. Specification of fluids

3.2.4. Hydraulic oil



For use in the hydraulic system of the machine, only high-quality hydraulic oils of output class according to ISO VG 46 HVLP (equal to DIN 51524 part 3 HVLP).

Standardly refill the machines with hydraulic oil of kinematic viscosity 46 mm²/s at the temperature of 40 °C (104 °F) ISO VG 46. This oil is the most suitable one to use in the broadest range of ambient temperatures.

Synthetic hydraulic oil

Hydraulic system can be filled with synthetic oil, that is completely degradable by microorganisms found in water and soil in case of leak. Hydraulic oil on the basis of HE ester, HEES category according to ISO 15380, can only be used.



When changing over from mineral oil to synthetic or when mixing oils of different brands, always consult the procedure with the oil manufacturer or dealer!

3.2.5. Lubricating grease

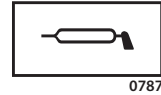





For lubrication of the machine, lubricants must be used according to:

ISO 2137

DIN 51 502

3.3. Fills

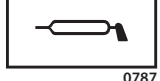
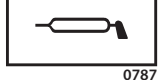
Fills of...	Type of fill	Quantity l (gal US)	Brand
Engine	Engine oil according to chapter 3.2.1.	3,4 (0,9)	 2412
Fuel tank	Diesel according to chapter 3.2.2.	28 (7,4)	 2151
Hydrostatic system	Hydraulic oil according to chapter 3.2.4.	16 (4,23)	 2158
Engine cooling system - coolant	All year round - anti-freeze liquid according to chapter 3.2.3.	1,2 (0,3)	 2152
Joint bearings - joint and steering cylinder	Plastic grease according to chapter 3.2.5.	as required	 0787
Vibrator bearings	Plastic grease according to chapter 3.2.5.	lifelong filling	 0787

3.4. Lubrication and Maintenance Chart



Every 10 hours of operation (daily)	
3.6.1.	Checking fuel level
3.6.2.	Engine oil level check
3.6.3.	Engine cooling liquid level check
3.6.4.	Hydraulic tank oil level check
3.6.5.	Cleaning the hydraulic oil cooler
3.6.6.	Air filter check
3.6.7.	Cleaning of the water separator
3.6.8.	Scrapers
3.6.9.	Check of the near and remote halt function
3.6.10.	Check of the safety bar function
Every 50 hours of operation	
3.6.11.	Inspection of brakes
3.6.12.	Battery check
After 50 hours of operation	
3.6.14.	Check of the fan and engine belt condition *
3.6.15.	Replacement of engine oil and filter *
Every 100 hours of operation (weekly)	
3.6.13.	Lubricating steering cylinder, bearing
Every 250 operating hours (3 months)	
3.6.14.	Check of the fan and engine belt condition
3.6.15.	Replacement of engine oil and filter
Every 500 hours of operation (6 months)	
3.6.16.	Replacement of fuel filters
3.6.17.	Air filter cartridge replacement
After 500 hours of operation	
3.6.18.	Exchanging hydraulic oil and filter **

Every 1000 hours of operation (1 year)	
3.6.18.	Exchanging hydraulic oil and filter
3.6.19.	Engine cooling liquid change
3.6.20.	Cleaning the fuel tank
3.6.21.	Valve clearance adjustment
3.6.22.	Check of swing support
3.6.23.	Check of articulation joint
3.6.24.	Checking the damping system
Maintenance - As Needed	
3.6.25.	Replacement of engine cover gas struts
3.6.26.	Cleaning the machine
3.6.27.	Check of the screw connection tightening
<p>* First after 50 hours</p> <p>** First after 500 hours</p>	

LUBRICATION AND SERVICE PLAN

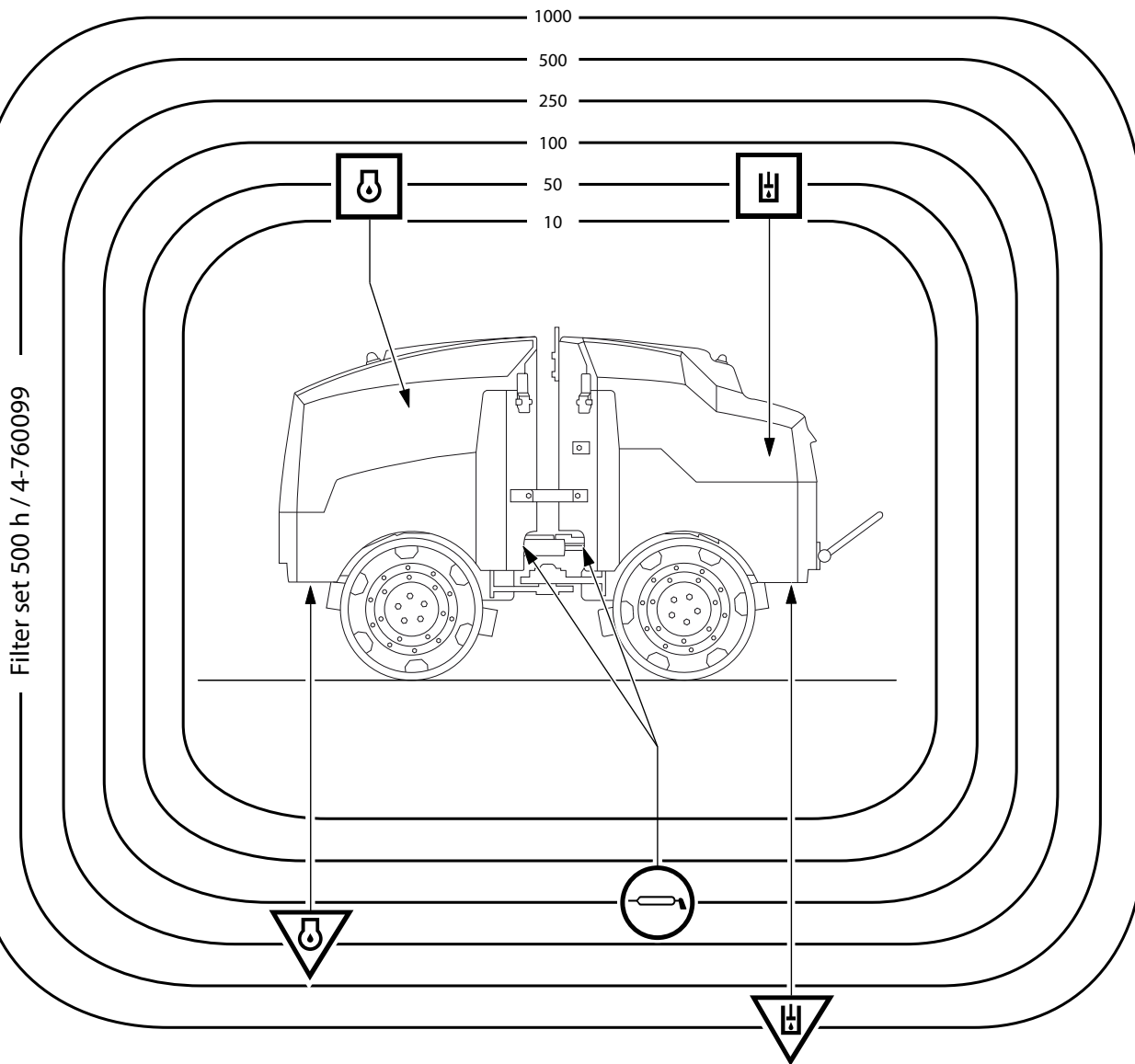
□	CONTROL
○	LUBRICATE
▽	EXCHANGE

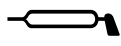

	Engine oil:	SAE 15W/40	API CF, ACEA E3-E5
	Hydraulic oil:	ISO VG 46 HVLP	
	Grease:	ISO 2137	DIN 51 502

555084en

3.6. Individual Operations of Maintenance

Carry out lubrication and maintenance on regular basis and repeatedly in the intervals as per daily reading on the counter of hours actually worked.

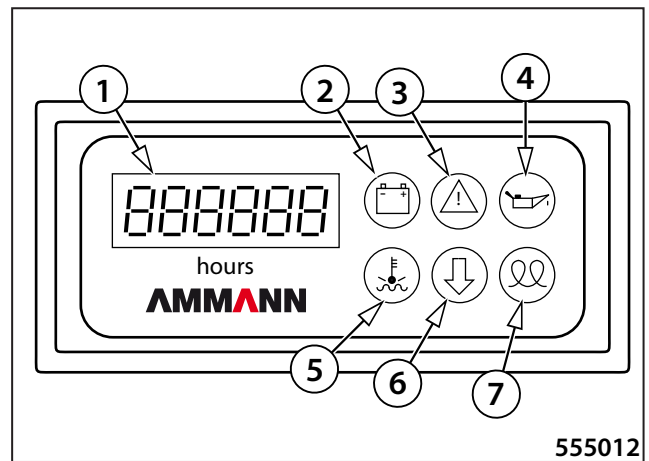

This Manual states only the basic information about the engine, other data are given in the Engine Operation and Maintenance Manual which is part of the Documentation supplied with the Machine.



Follow the instructions given in the Engine Operation and Maintenance Manual!

Tighten the removed or loosened bolts, plugs, threaded joints of the hydraulics, etc. with tightening torque according to the Chart in par. 3.6.27. unless another value is provided with the respective operation.



Carry out maintenance with the Machine placed on flat, paved surface, and secured against any self-motion, always with the engine off, and key removed from the ignition box and with the wiring cut off (unless otherwise required). Only carry out lubrication, maintenance and adjustment on a machine marked with "Machine in repair" tag!

Following the first 50 hours of operation of the new Machine (following a major overhaul) carry out as per:

- 3.6.14. Check of the fan and engine belt condition
- 3.6.15. Replacement of engine oil and filter

Following the first 500 hours of operation of the new Machine (following a major overhaul) carry out as per:

- 3.6.18. Exchanging hydraulic oil and filter

3.6. Individual Operations of Maintenance

Every 10 hours of operation (daily)

3.6.1. Checking fuel level

- Open the hood.
- Check the level in the plastic tank.
- If needed, fill the fuel tank with diesel fuel up to the lower edge of the filler neck.
- The tank holds 28 liters of diesel fuel.



No smoking at work!

Check the tightness of the fuel tank and fuel system.



Retain any fuel flowing out.



3.6.2. Engine oil level check

- Wait approx. 5 min. until oil runs down to the engine sump.
- Take out the oil dipstick (1), wipe it, insert fully back and take it out again to read out the oil level.



- Keep the level within the range of gauge marks pressed in the dipstick. The lower mark L (Low) marks the lowest possible oil level, the upper mark H (High) the highest one.
- Top up the engine oil at one of the two oil filler necks.
 - Filler neck on the left-hand side of the engine (1).
 - Filler neck on the engine (2).
- Check the engine for leakage, repair possible causes.
- Check the engine for damaged and missing parts and for changes in appearance.

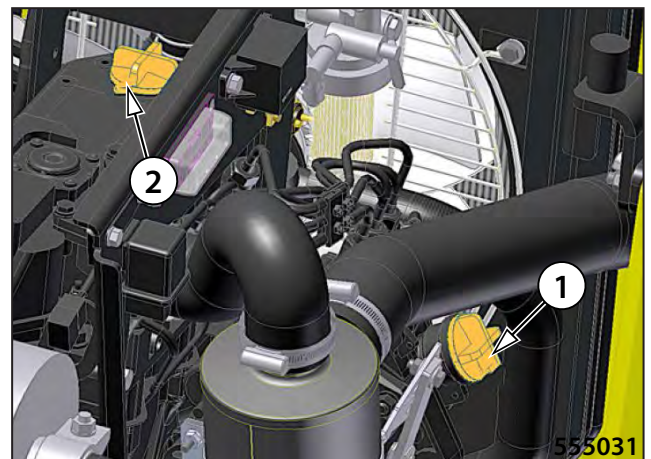

Note:

The total amount of oil in the engine is 3.4l (0.9 US gal).



Do not use the engine unless the oil level in the engine is correct.

Check oil when it is cooled down.

Refill the identical type of oil to chapter 3.2.1.



Avoid leakage of oil to the soil.

3.6. Individual Operations of Maintenance

3.6.3. Engine cooling liquid level check

- Let cooling liquid cool down to less than 50 °C (120 °F).
- You can read off the level of coolant on the expansion tank display. The water level must be between the top (FULL) and bottom (LOW) marks.
- Top up coolant as required.

Note:

The total amount of engine coolant is 1.2l (0.3 US gal).



Dismantle the filling plug only when the temperature of engine cooling liquid falls to less than 50 °C (120 °F). If you open it at higher temperatures, you risk scalding by steam or by cooling liquid due to the inner overpressure.



The level must not fall below the level indicator eyesight. Refill only cooling liquids containing the frost-resistant agents on the identical basis, according to chapter 3.2.3. Do not add additives eliminating untightness of the cooling system to the engine cooling liquid! Do not refill cold cooling liquid into hot engine. Engine castings might get damaged. In case of larger losses, find the location of cooling system leaks and repair the cause.



3.6.4. Hydraulic tank oil level check

- Always check the hydraulic oil level at operating temperature with the engine running.
- Place the machine on level ground.
- Let the machine continue to idle.
- Check the oil level in the inspection window.
- The ideal oil level is when the gauge is half-full.

Topping up hydraulic oil

- Remove the screw lid (1) on the filler neck.
- Refill hydraulic oil if necessary.
- Reinstall the screw lid (1).

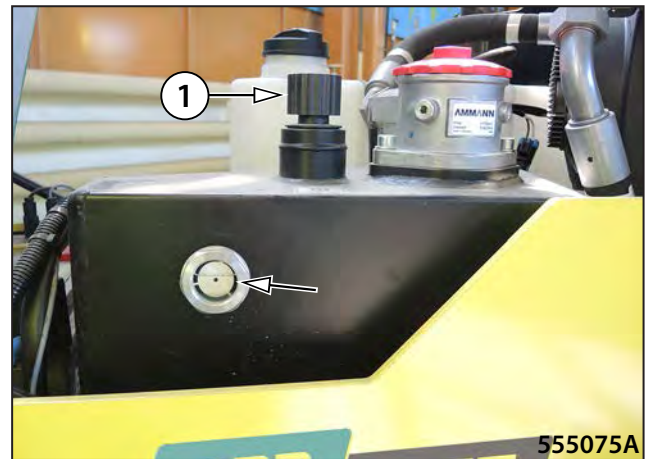

Important: Always grease the O-ring before screwing it in place.

Check oil when it is cooled down.

Refill the identical type of oil to chapter 3.2.4.



Avoid leakage of oil to the soil.

3.6. Individual Operations of Maintenance

3.6.5. Cleaning the hydraulic oil cooler

- Check the cooling ribs of the hydraulic oil cooler for dirt and clogging.
- Clean the ribs with water or blow them out with compressed air.
- In case of work in very dusty conditions clean the radiator daily. Clogged radiators will result in lower cooling capacity and increasing temperatures of engine cooling liquid and hydraulic oil.



Do not use cleaner with too high pressure so as not to damage radiator honeycombs.

In case of contamination of the radiator by oil products, use a cleaning agent and proceed according to the manufacturer's instructions! Find the cause of contamination!

No smoking at work!

Check the tightness of the hydraulic circuit.



Follow environmental standards and regulations when cleaning the machine!

Clean the machine in a site equipped with an intercepting system for cleaning agents so that the soil and water sources are not contaminated!

Do not use forbidden cleaning agents!



3.6.6. Air filter check

- If a red ring appears on the soiling display (1) during operation of the machine, you must:
 - replace the air filter insert according to chap. 3.6.17.

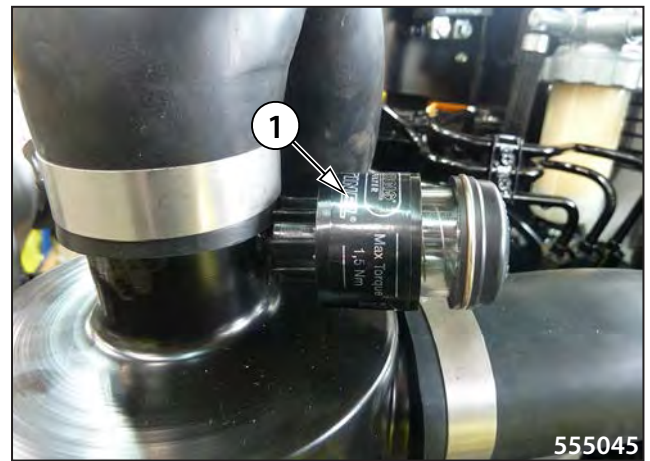

Check the air intake for: Soiling: clean the intake opening.

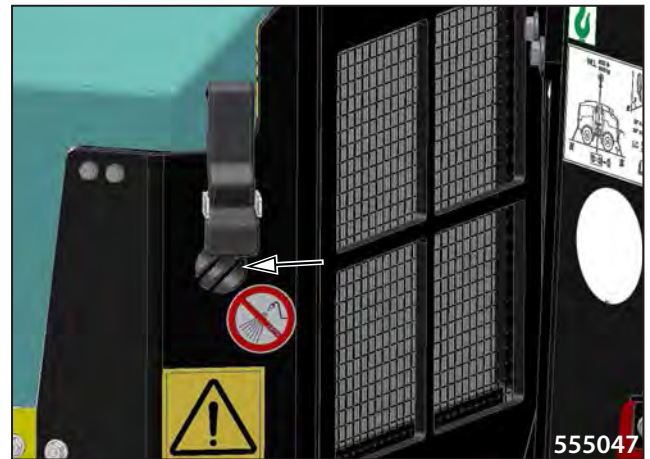

- Clean the exit slit, press to remove any dust trapped.

Note

Possible dust trapped in the dust valve is automatically emptied during operation of the machine.



Replace the dust valve immediately if it is damaged!

Dust valve

Order number: 1227914



3.6. Individual Operations of Maintenance

3.6.7. Cleaning of the water separator

- If the red ring leaves the bottom, pour out water from the separator.
- Close stop cock (3).
- Unscrew the filter housing (2).
- Clean filter element (1).
- Screw the filter housing (2) on.
- Open stop cock (3).
- Turn the ignition on. The fuel pump bleeds the system automatically.



No smoking at work!

Check the tightness of the water separator.



Avoid leakage of liquid to the soil.

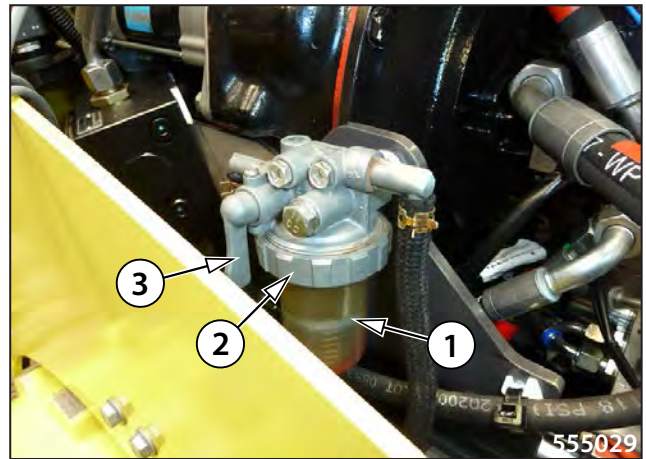

3.6.8. Scrapers

- Before driving, adjust the drum scraper so that there is a clearance of about 5 mm between the drum and the scraper.

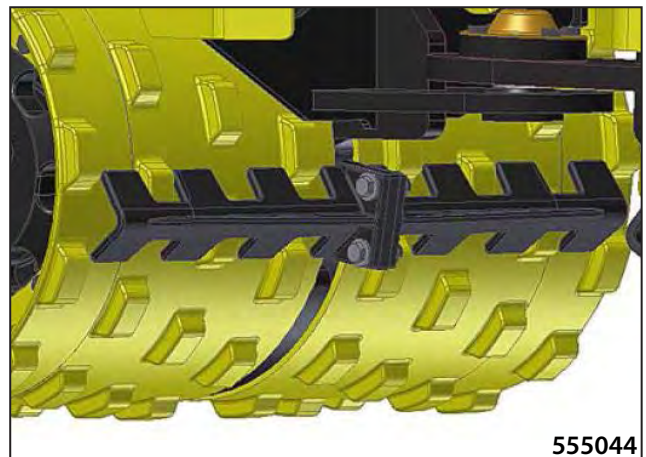

3.6.9. Check of the near and remote halt function

- Turn the key to the II position (preheating). The engine must not be started.



The III position (start) must not be activated.



- Gradually move closer with the infrared remote control to a distance of less than 2 metres to the rear part, front part and side part of the machine from the infrared sensor and each time move the control stick of the left/right steering angle (4) to the right.
- The LED safety bar indicator (6) on the display unit must always light up.



If the infrared remote control is not functional or the safety bar indicator on the display unit does not light up, it is forbidden to operate the machine until the fault is removed.

In order to use the infrared remote control properly, follow the instructions given in Chapter 2.6.2.3.

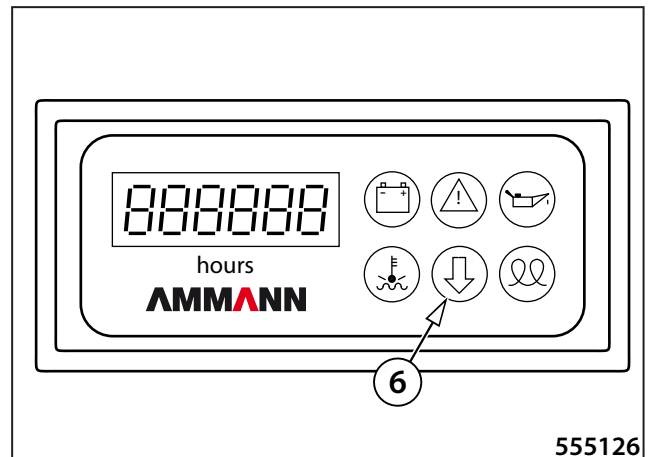

3.6. Individual Operations of Maintenance

3.6.10. Check of the safety bar function (optional equipment)

- Turn the key to the II position (preheating). The engine must not be started.



The III position (start) must not be activated.



- Pushing the safety bar upwards activates and closes the near halt switch.
- The LED safety bar indicator (6) on the display unit must always light up. The safety bar indicator is continuously on the whole time the safety bar is connected.



If the safety bar is not functional or the safety bar indicator on the display unit does not light up, it is forbidden to operate the machine until the fault is removed.

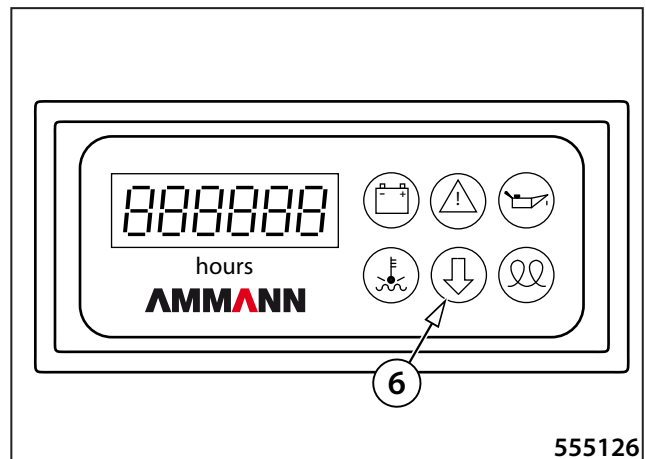

Every 50 hours of operation

3.6.11. Inspection of brakes

- The function of the brakes must be checked periodically.
- The cable / connector Y9, which must be disconnected for the brake test, is located at the front under the hood.



- Put the machine into the work gear.
- Disconnect connector Y9 (1) from the connector housing at the magnet.
- Perform the forwards and backwards driving functions using the infrared sensor.
- If a brake is defective, the corresponding drum will rotate.

Note:

If a brake is defective, the machine is no longer safe for operation. Contact your authorized dealer and have the machine repaired professionally.

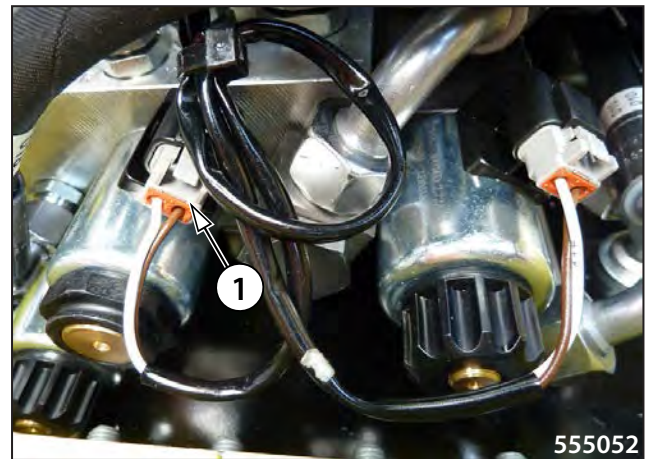

3.6. Individual Operations of Maintenance

3.6.12. Battery check

- Stop the engine.
- Clean the surface of batteries.
- Check the condition of poles and terminals (1) and clean them. Slightly wipe terminals with grease.

MAINTENANCE-FREE BATTERY

- In case of a maintenance-free battery (the battery has no freely accessible plugs), only the no-load voltage on terminals is checked. The batteries cannot be replenished. If the no-load voltage is 12.6 V and more, the battery is fully charged. If the no-load voltage is below 12.4 V, the battery should be charged immediately. After the battery is charged, leave it to stand for 2–3 hours and then measure the voltage again. It is recommended to be mounted 24 hours after charging.

Note:

The no-load voltage is the voltage measured at the terminals of the battery which was at rest for at least 12 hours – was neither charged nor discharged.

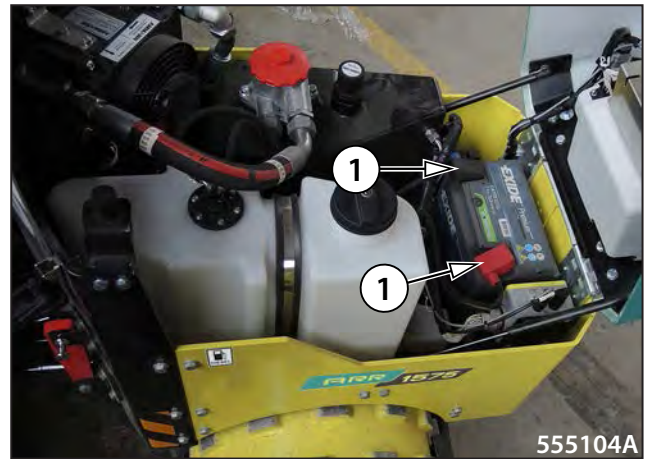

Keep the batteries dry and clean.

Do NOT disconnect battery while the engine runs.

When handling with the battery, always follow battery Manufacturer's Manual!

Use rubber gloves and eye protection aids when handling the battery.

Use proper clothing to protect your skin against any electrolyte stain.

When there is eye contact with electrolyte immediately flush affected eye with large amounts of water for a few minutes. Get prompt medical attention.

When there is electrolyte ingestion, drink max amount of milk, water, or solution of calcined magnesia in water.

During skin contact with electrolyte, remove clothing, including shoes, flush affected points as soon as possible with soap water or solution of soda and water. Get prompt medical attention.

Do NOT eat, drink or smoke while at work!

After work is completed, wash your hands and face thoroughly with water and soap!

Do NOT check a wire is energized by touching Machine frame.

Disconnect the battery before its repair, or when about to handle the wires and electric devices within the wiring circuit so to avoid a short circuit.

When disconnecting the battery, please disconnect cable with (-) pole first. When connecting, you must connect (+) pole first.

Making direct conductive connection between battery's both poles you will cause a short circuit with battery explosion hazard.



Do NOT turn over the batteries, electrolyte may pour out from degassing batteries.

When there is electrolyte spillage, rinse the affected place with water, and neutralize with lime.

Hand over old batteries that do not work for their disposal.

Every 100 hours of operation (weekly)

3.6.13. Lubricating steering cylinder, bearing

- Rotate the hydraulic cylinder steering fully to the stop in order to grease the cylinder.
- Steer the machine briefly to the right and the left. This causes the bearing to be unloaded.
- Clean the grease nipple (1) before greasing.
- Connect the grease gun to the grease nipple.
- Press grease into the bearing until it visibly begins to ooze out.
- Put the protective cover back on.

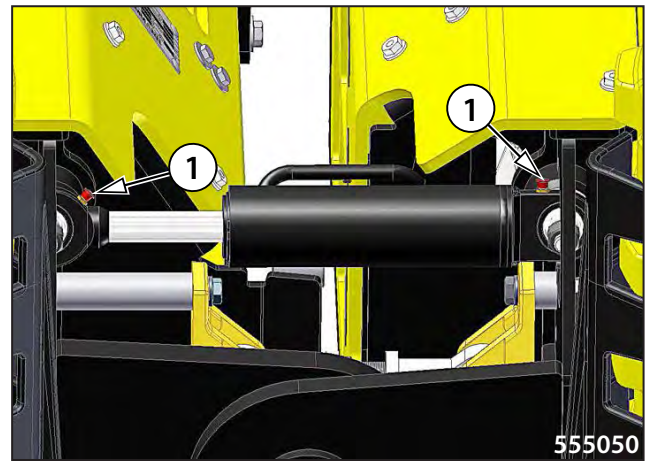

Note:

Regrease the bearing after every cleaning / steam cleaning of the machine.

3.6. Individual Operations of Maintenance

Every 250 operating hours (3 months)

3.6.14. Check of the fan and engine belt condition



First carry out after 50 hours.

- Check the ventilator visually. In case of any damage (e.g. missing parts of the material, cracks, changes in shape etc.) replace the ventilator.

Fan

Order number: 1-952338

- Check visually the belt, for intersecting cracks. Longitudinal (direction of belt length) cracks that intersect with traverse cracks are not acceptable. Replace the belt if it is frayed or has pieces of material missing.



The engine must be stopped for check of tightness of the belt.

- Use your thumb to press the belt by the force of 100 Nm. Check the slack of the belt at the point illustrated in the picture. It should be between 10-14 mm.

Belt

Order number: 1183743

- If needed, tighten the belt by releasing the bolt and shifting the alternator.
- Let the engine run for five minutes and then check the belt for correct tightness.

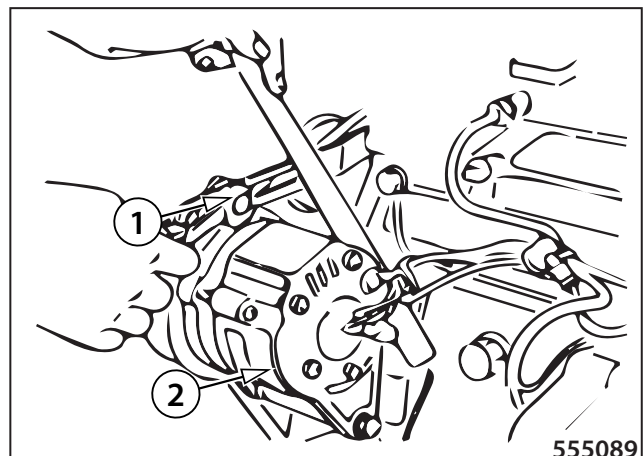
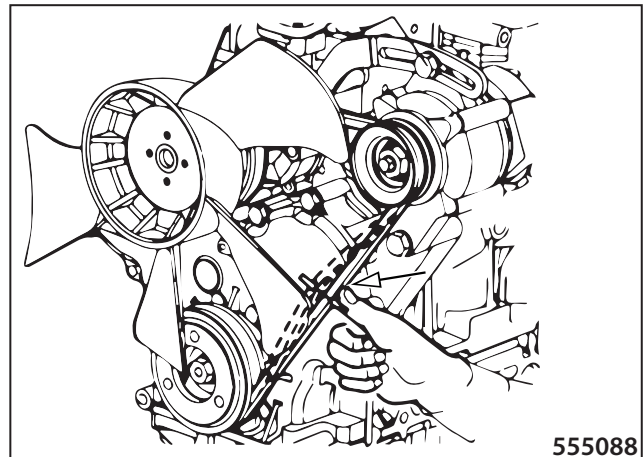

3.6.15. Replacement of engine oil and filter



First carry out after 50 hours.

Draining engine oil

- The engine oil drain (1) is located under the chassis at the front left.
- Place a container under the drain.
- Open the union by turning it anti-clockwise (size 27 wrench).
- The oil starts to flow out immediately.



Replacement of engine oil filter

- Loosen the filter (1) by hand or using a filter wrench.
- The oil starts to flow out immediately. It's best to place a rag under it beforehand.
- Replace oil filter.
- Install in accordance with instructions (see filter packaging or filter housing).
- Screw the complete filter back in place.

Engine oil filter

Order number: 1-954075



Note:

- After refilling, start the engine for 2 - 3 min. Check tightness of drain plug and filter.
- Stop the engine, wait for approx. 5 min. until oil runs down to the engine sump. Then check the level with oil dipstick.

3.6. Individual Operations of Maintenance

- Refill engine oil through one of two filling ports.
 - Oil filling port on the left engine side (1)
 - Oil filling port on the engine (2)
- Keep the level within the range of gauge marks pressed in the dipstick. The lower mark shows the lowest possible oil level, the upper mark the highest possible oil level.

Note:

The total amount of oil in the engine is 3.4l (0.9 US gal).



Beware of scalding when draining hot oil. Let oil cool down to less than 50 °C (122 °F).

Follow the fire safety measures!



**Use recommended filters - see Spare parts catalogue.
Use recommended oil - see chapter 3.2.1.**



**Collect drained oil; do not let it soak into the ground.
Used oil and filters are environmentally dangerous waste
- have them liquidated.**

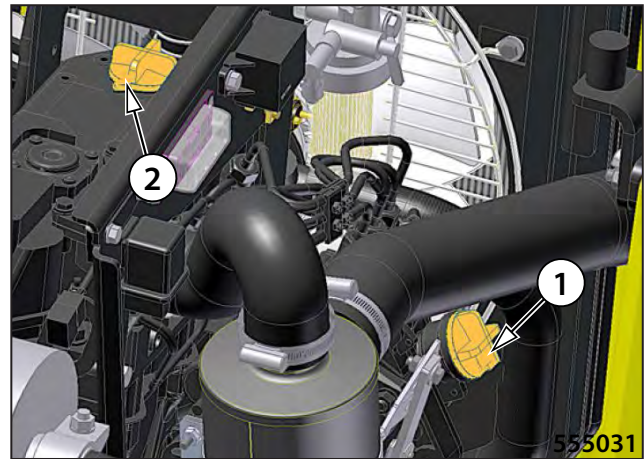

Every 500 hours of operation (6 months)

The set of filters after 500 operating hours can be ordered under the order number 4-760099. For the list of all spare parts, see the table in the end of this publication.

3.6.16. Replacement of fuel filters

- Close stop cock (3). Move to OFF (C).
- Unscrew the filter housing (2).
- Remove the old filter element (1).
- Replace the O-ring.
- Insert new filter element (1).

Fuel filter element

Order number: 1-954197

O-ring

Order number: 76-1021035520

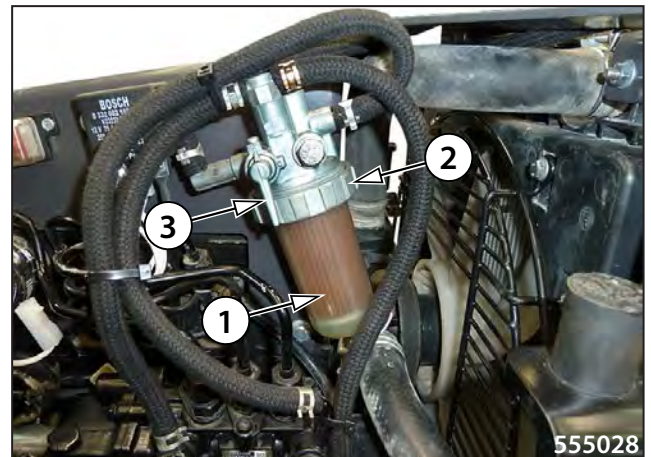

- Screw the filter housing (2) on.
- Open stop cock (3). Move to ON (O).

3.6. Individual Operations of Maintenance

- Close the stop valve (3).
- Unscrew the filter housing (2).
- Vyměňte kroužek O.
- Replace the filter cartridge (1).

Fuel filter element

Order number: 1-954195

O-ring

Order number: 76-10210355520

- Reinstall the filter housing (2).
- Open the stop valve (3).
- Turn the ignition on. The fuel pump vents the system automatically.

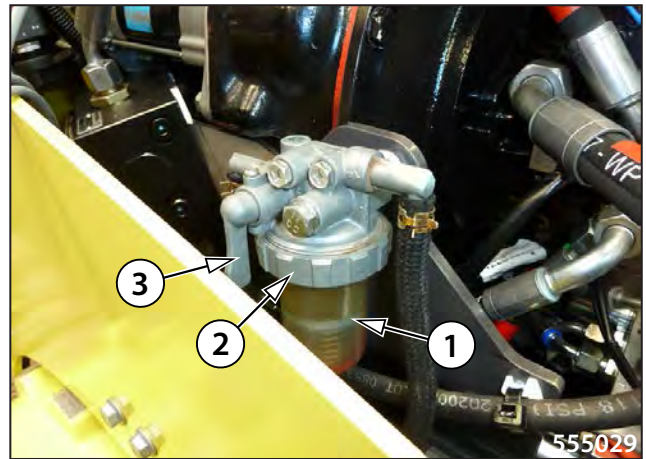

Use original filters required.

No smoking at work!

Do NOT tighten the filters with force.



Retain any fuel flowing out.

Store used filters inside separate container, and hand over for their disposal.

3.6.17. Air filter cartridge replacement

- If a red ring appears on the soiling display (1) during operation of the machine, you must replace the cartridge, however at the latest after 500 engine hours. In case of work in a very dusty environment, shorten the filter element replacement intervals.



The manufacturer recommends that the elements should not be cleaned due to a decrease in the filtration capacity by up to 40% and possible damaging of elements resulting from the cleaning.

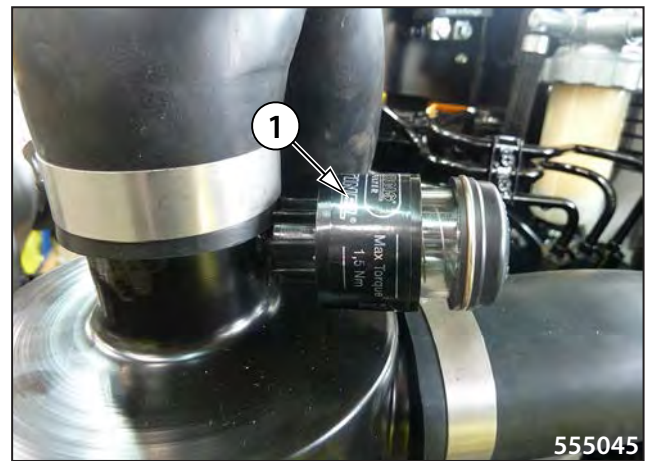

The air filter is located on the left side of the engine.

- Remove the wing nut (2) with the cover.

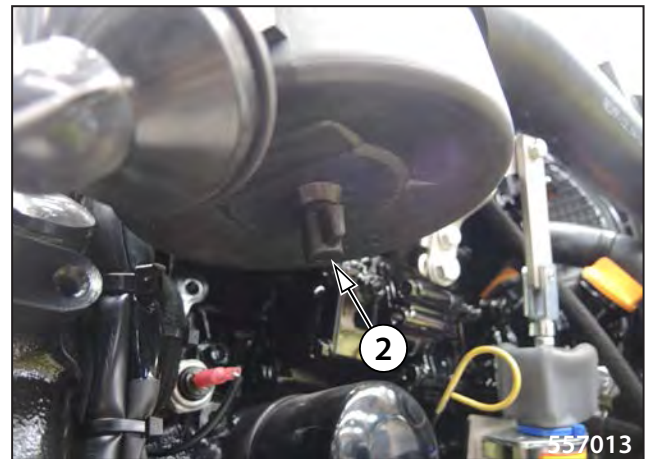

- Unscrew another winged nut.



- Remove the main cartridge of the air filter (3).



3.6. Individual Operations of Maintenance

- Unscrew the nut and replace the filter cartridge.

Filter element

Order number: 1300309



- Install a new main cartridge. Tighten the winged nut.

Air filter element

Order number: 1300308

Note:

If the machine is used on very dusty surfaces, the air filter must be checked for clogging once per week.

When replacing the cartridges, take care that no dirt enters the suction hose.



- Check the air intake for: Soiling: clean the intake opening.

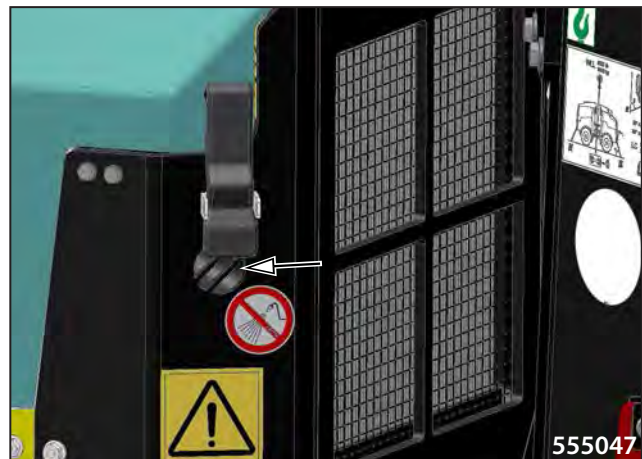

Do not clean the inside of the cleaner by pressure air; dust might get into the engine inlet piping.

Use original elements only.

When washing the machine, make sure water cannot pour into the air cleaner.

In case of absorbing water, exchange main element. Dry the cleaner body.

Replace defective vacuum valve immediately!

Do not operate the machine with damaged cleaner body or cover.

Every 1000 hours of operation (1 year)

3.6.18. Exchanging hydraulic oil and filter



First carry out after 500 hours.

Replacing the hydraulic oil filter

- Remove the filter lid.
- Unlock the filter element.
- Lift the filter element out of the filter housing.
- Dispose of the filter element in an ecologically appropriate manner.
- Place the new filter element in the proper position. Observe the position of the locking cam.
- Turn the filter element fully clockwise to the stop.

Set of hydraulic oil filters

Order number: 1182946

- Lightly oil the sealing ring on the filter lid.
- Put the filter lid in place.
- Tighten the lid with a torque wrench (max. torque, 20 Nm).

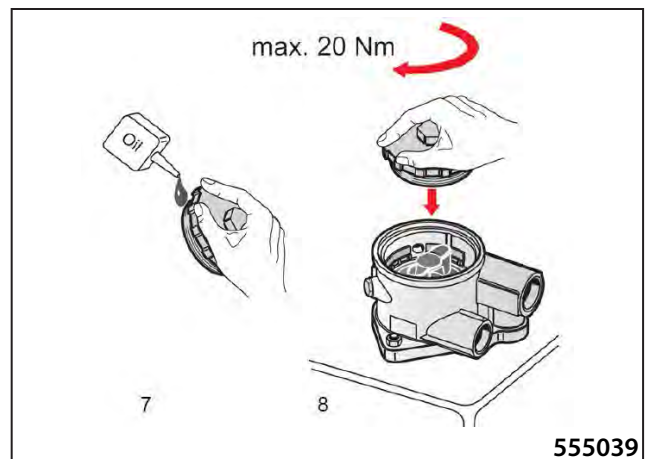
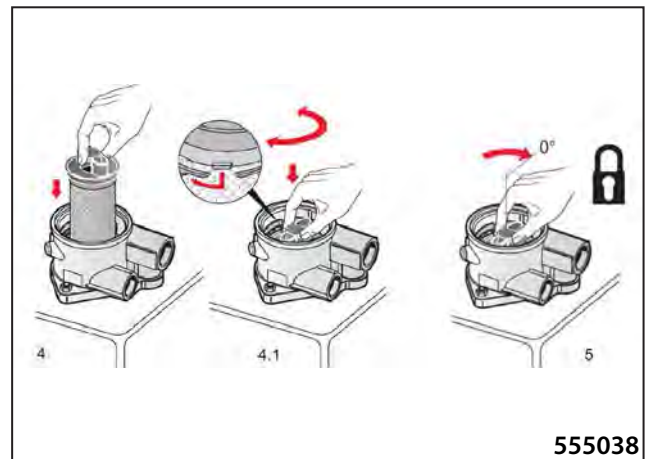
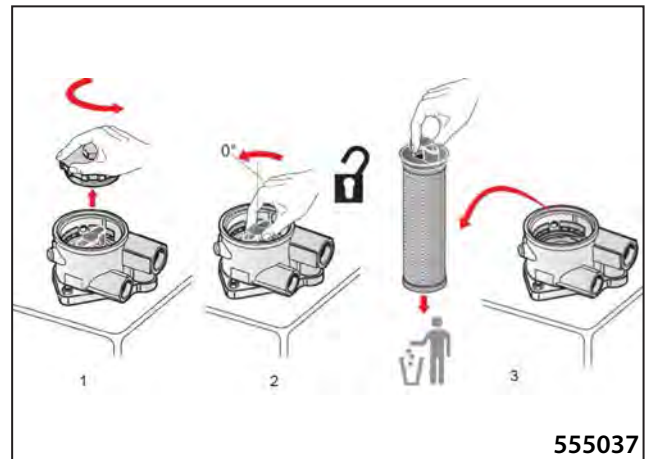

Draining the hydraulic oil

Note:

Only drain the hydraulic oil at operating temperature.

Residues in the tank will be flushed out with the oil.

- Place a container (with at least a 30 liter capacity) under the hydraulic oil drain.
- Remove the hydraulic oil tank lid (1).



3.6. Individual Operations of Maintenance

- Remove the plug (2) from hydraulic tank.
- Allow the oil to drain into the container.
- Install the screw plug (2).
- Tighten the screw connection hand tight.
- Tighten the screw connections in the hydraulic tank hand tight.



Filling the hydraulic circuit:

- Fill hydraulic oil through the port into the tank.
- Replace the venting filter (1) for a new one.

Breather filter

Order number: 1242184

- Apply thin film of oil on the sealing ring in the lid.
- Install new filter in the tank.



Exchange oil when it is warm, preferably after the machine stops.

Let drained oil cool down to less than 50 °C (122 °F).

Refill the identical type of oil.



Avoid leakage of oil to the soil.

3.6.19. Engine cooling liquid change

- Remove the drain plug and drain the coolant.

Note:

- The total volume of the engine coolant is 1.2 litres (0.32 US gal).



- Open the cooling system by removing the overpressure plug on the expansion tank.
- Fill the cooling system through the opening in the expansion tank.



Remove the filling plug only after the temperature of the engine coolant drops below 50 °C (120 °F). If you remove the plug at a higher temperature, there is a risk of scalding caused by steam or coolant due to internal overpressure.



The level must not drop below the lower mark.

Refill only with a coolant containing antifreeze agents on the same basis according to Chapter 3.2.3.

Do not put any additives for the repair of cooling system leakage into the engine coolant!

Do not refill cold coolant into a hot engine. There is a danger of damage to the engine castings.

In case of larger losses, find out where the cooling system leaks and repair the cause.



Avoid leakage of oil to the soil.

3.6. Individual Operations of Maintenance

3.6.20. Cleaning the fuel tank

- Over time, condensation water gathers in the fuel tank. It must be drained once a year.
- Remove the plug (1) from fuel tank.
- Place a container under the drain tap.
- Drain off the diesel.
- Inspect and clean the tank's inner area.
- Install the screw plug (1). Tighten the screw connection hand tight.

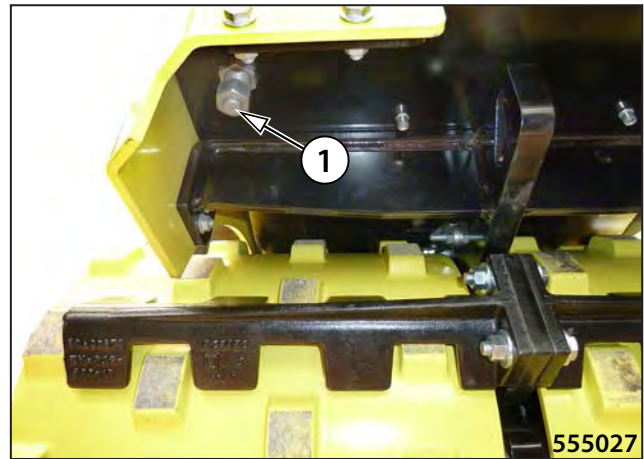

- Fill the fuel tank with diesel oil up to the lower edge of the filler neck.



No smoking at work!



Retain any fuel flowing out.



3.6.21. Valve clearance adjustment

- Call YANMAR service department to adjust the engine valves. For contact points, please refer to Engine Operation and Maintenance Manual.

Note:

Further regular maintenance (check of injection and venting of the crankcase after 1500 engine hours, emission check after 3000 engine hours) should be consulted with Yanmar service.

3.6.22. Check of swing support

- Check the swing support once a year for excessive play.
- Lift the machine with a crane for 1-point lifting eye.
- Visually check the clearance of the pendulum bearing by applying pressure on the machine alternatively upwards and downwards.

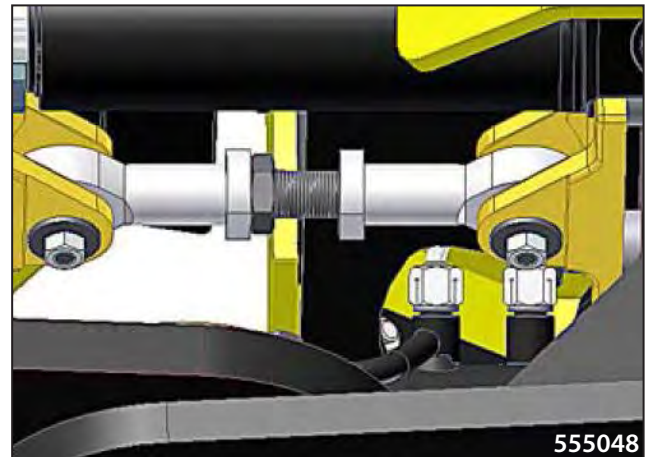

3.6. Individual Operations of Maintenance

3.6.23. Check of articulation joint

- Check the articulation joint once a year for excessive play.
- Lift the machine with a crane for 1-point lifting eye.
- Visually check the clearance of the articulated joint by applying pressure on the machine alternatively upwards and downwards.



3.6.24. Checking the damping system

Check the condition of the rubber-metals, the strength of the bond between metal and rubber.



Replace if damaged.

Check the tightness of screws and nuts.

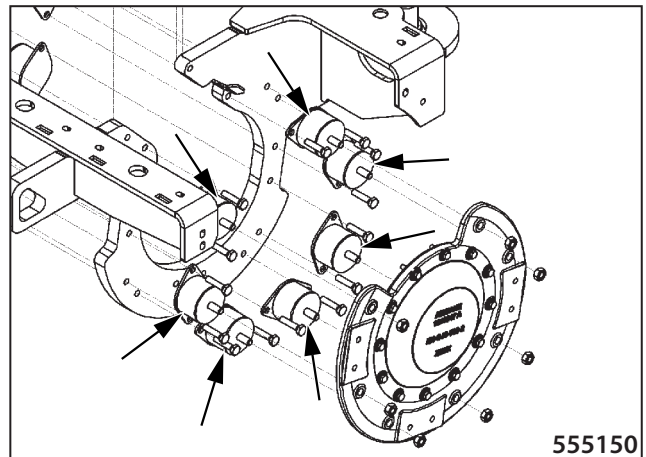

Drum rubber-metal

Order number:1217092

Maintenance - As Needed

3.6.25. Replacement of engine cover gas struts

- Gas struts are maintenance-free! They require no maintenance such as lubrication. They are designed for the respective requirements and work trouble-free for many years. When the gas springs fail to fulfil their function, replace them for new ones.

Gas springs (2 pcs)
Order number: 1205428



Before you begin replacing the gas struts, secure the engine bonnet against spontaneous fall.

There is a risk of injury!

Removal

- Use a screwdriver to lift the clips.
- Pull the gas strut away from the ball joint.

Installing

- The new gas struts can easily be installed by pressing them onto the ball joint.
- The clamp must be seated securely afterward.



Gas struts should not be installed if they have been damaged through mechanical manipulation.

Use genuine parts only!



If gas struts are no longer needed, they must be disposed of in an environmentally appropriate manner.

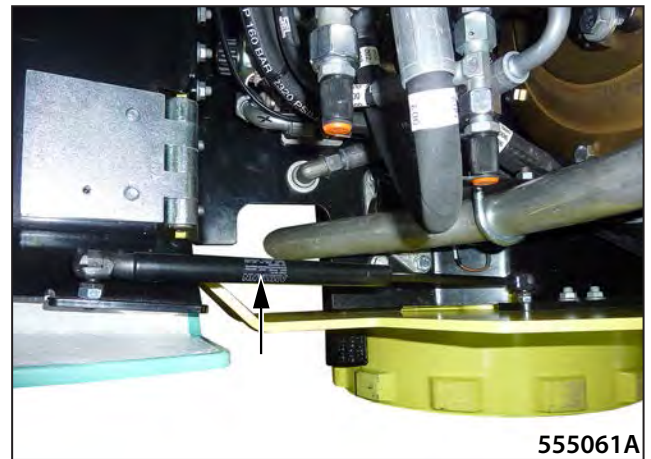

3.6. Individual Operations of Maintenance

3.6.26. Cleaning the machine

- Clean the machine from major impurities after finishing your work.
- Perform overall cleaning regularly at least once in a week.



Blind all openings into which the cleaning agent might penetrate (e.g. engine inlet opening) prior to pressure water washing. Remove these blinders after washing the machine.

Do not expose electric parts or insulation material to direct water or steam flow. Always cover such materials (inside of the alternator etc.).

Work with stopped engine.

Do not use aggressive and highly inflammable cleaning agents (e.g. petrol or highly inflammable materials).



Follow environmental standards and regulations when cleaning the machine!

Clean the machine in a site equipped with an intercepting system for cleaning agents so that the soil and water sources are not contaminated!

Do not use forbidden cleaning agents!

3.6.27. Check of the screw connection tightening

- Check regularly that no bolted connections have been slackened. Use torque spanners to tighten.

	Torque					Torque			
	For 8,8 Bolts (8G)		For 10,9 Bolts (10K)			For 8,8 Bolts (8G)		For 10,9 Bolts (10K)	
Thread	Nm	lb ft	Nm	lb ft	Thread	Nm	lb ft	Nm	lb ft
M6	10	7,4	14	10,3	M18x1,5	220	162,2	312	230,1
M8	24	25,0	34	25,0	M20	390	287,6	550	405,6
M8x1	19	14,0	27	19,9	M20x1,5	312	230,1	440	324,5
M10	48	35,4	67	49,4	M22	530	390,9	745	549,4
M10x1,25	38	28,0	54	39,8	M22x1,5	425	313,4	590	435,1
M12	83	61,2	117	86,2	M24	675	497,8	950	700,6
M12x1,25	66	48,7	94	69,3	M24x2	540	398,2	760	560,5
M14	132	97,3	185	136,4	M27	995	733,8	1400	1032,5
M14x1,5	106	78,2	148	109,1	M27x2	795	586,3	1120	826,0
M16	200	147,5	285	210,2	M30	1350	995,7	1900	1401,3
M16x1,5	160	118,0	228	168,1	M30x2	1080	796,5	1520	1121,0
M18	275	202,8	390	287,6					

Values given in the Table are the torques at dry tread (at coefficient of friction = 0,14). Such values do NOT apply to a greased thread.

Table of torques used for cap nuts with sealing "O" ring - hoses

Spanner Size	Thread	Pipe	Torques for cap nuts incl. "O" ring - hoses					
			Nm			lb ft		
			Nominal	Min	Max	Nominal	Min	Max
14	12x1,5	6	20	15	25	15	11	18
17	14x1,5	8	38	30	45	28	22	33
19	16x1,5	8	45	38	52	33	28	38
		10						
22	18x1,5	10	51	43	58	38	32	43
		12						
24	20x1,5	12	58	50	65	43	37	48
27	22x1,5	14	74	60	88	55	44	65
		15						
30	24x1,5	16	74	60	88	55	44	65
32	26x1,5	18	105	85	125	77	63	92
36	30x2	20	135	115	155	100	85	114
		22						
41	36x2	25	166	140	192	122	103	142
46		28						
50	42x2	30	240	210	270	177	155	199
50	52x2	35	290	255	325	214	188	240
		38						
		42						

3.6. Individual Operations of Maintenance

Chart for torques of necks with sealing edge or with flat gasket

G -M	Neck Torques	
	Nm	lb ft
G 1/8	25	18
G 1/4	40	30
G 3/8	95	70
G 1/2	130	96
G 3/4	250	184
G 1	400	295
G 1 1/4	600	443
G 1 1/2	800	590
10 x 1	25	18
12 x 1,5	30	22
14 x 1,5	50	37
16 x 1,5	60	44
18 x 1,5	60	44
20 x 1,5	140	103
22 x 1,5	140	103
26 x 1,5	220	162
27 x 1,5	250	184
33 x 1,5	400	295
42 x 1,5	600	443
48 x 1,5	800	590

Chart for torques of plugs with flat gasket

G -M	Plug Torques	
	Nm	lb ft
G 1/8	15	11
G 1/4	33	24
G 3/8	70	52
G 1/2	90	66
G 3/4	150	111
G 1	220	162
G 1 1/4	600	443
G 1 1/2	800	590
10 x 1	13	10
12 x 1,5	30	22
14 x 1,5	40	30
16 x 1,5	60	44
18 x 1,5	70	52
20 x 1,5	90	66
22 x 1,5	100	74
26 x 1,5	120	89
27 x 1,5	150	111
33 x 1,5	250	184
42 x 1,5	400	295
48 x 1,5	500	369

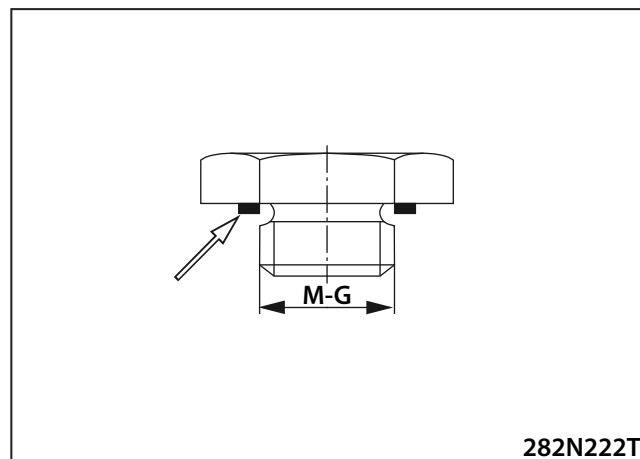
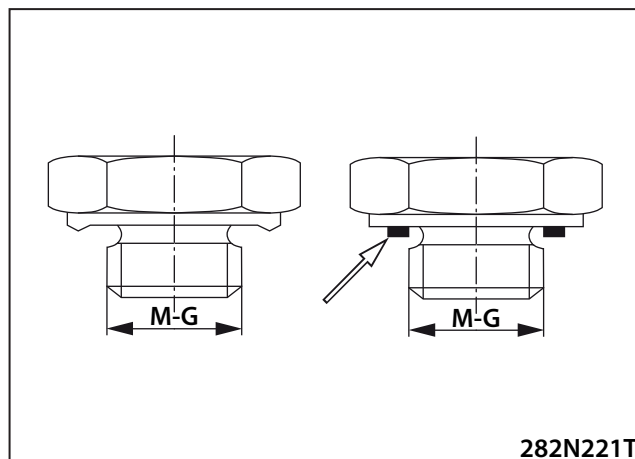



Usually, defects are caused by incorrect operation of the machine. Therefore, in case of any troubles read again properly through the instructions given in the operation and maintenance manual for the machine and engine. If you cannot identify the cause, contact a service department of an authorised dealer or the manufacturer.



Troubleshooting in hydraulic and electric systems requires knowledge of these systems; therefore a service department of an authorised dealer or the manufacturer should be called to solve these problems.

3.8. Annexes

3.8.1. Wiring diagram

Legend:

A1	Display ACEecon
A2	Display ACEecon
A3	Sensor, ACEecon
F11	Fuse, controller, supply
F12	Fuse, controller, outputs
F13	Fuse, display unit, shutdown bar
F14	Fuse, hydraulic oil cooler
F21	Fuse, pull-in solenoid
F22	Fuse, diesel pump, alternator
F23	Fuse, operating speed
F24	Fuse, pre-heating coil
F25	Fuse, "2nd solenoid"
G1	Alternator
G2	Battery
K1	Relay, ignition
K2	Relay, starting interlock
K3	Timer relay
K4	Relay, pull-in solenoid
K5	Relay, operating speed
K6	Relay, pre-heating coil
K7	Relay, hydraulic oil cooler
K11	Relay, "solenoid driver"
M1	Starter motor
M2	Diesel pump
M3	Hydraulic oil cooler
N1	Machine controller
N2	Display unit
N3	Infrared remote control
P1	Front infrared sensor
P2	Rear infrared sensor
R1	Pre-heating coil
S1	Switch, ignition switch
S21	Sensor, engine oil pressure
S22	Sensor, coolant temperature
S24	Sensor, shutdown bar
S25	Sensor, hydraulic oil temperature
Y1	Magnet, pull-in / holding solenoid
Y2	Magnet, operating speed
Y3	Magnet, drive pump, forwards
Y4	Magnet, drive pump, backwards
Y5	Valve, steering, left
Y6	Valve, steering, right
Y7	Valve, large amplitude vibration
Y8	Valve, small amplitude vibration
Y9	Valve, locking brake
Y11	Magnet, "2nd solenoid"

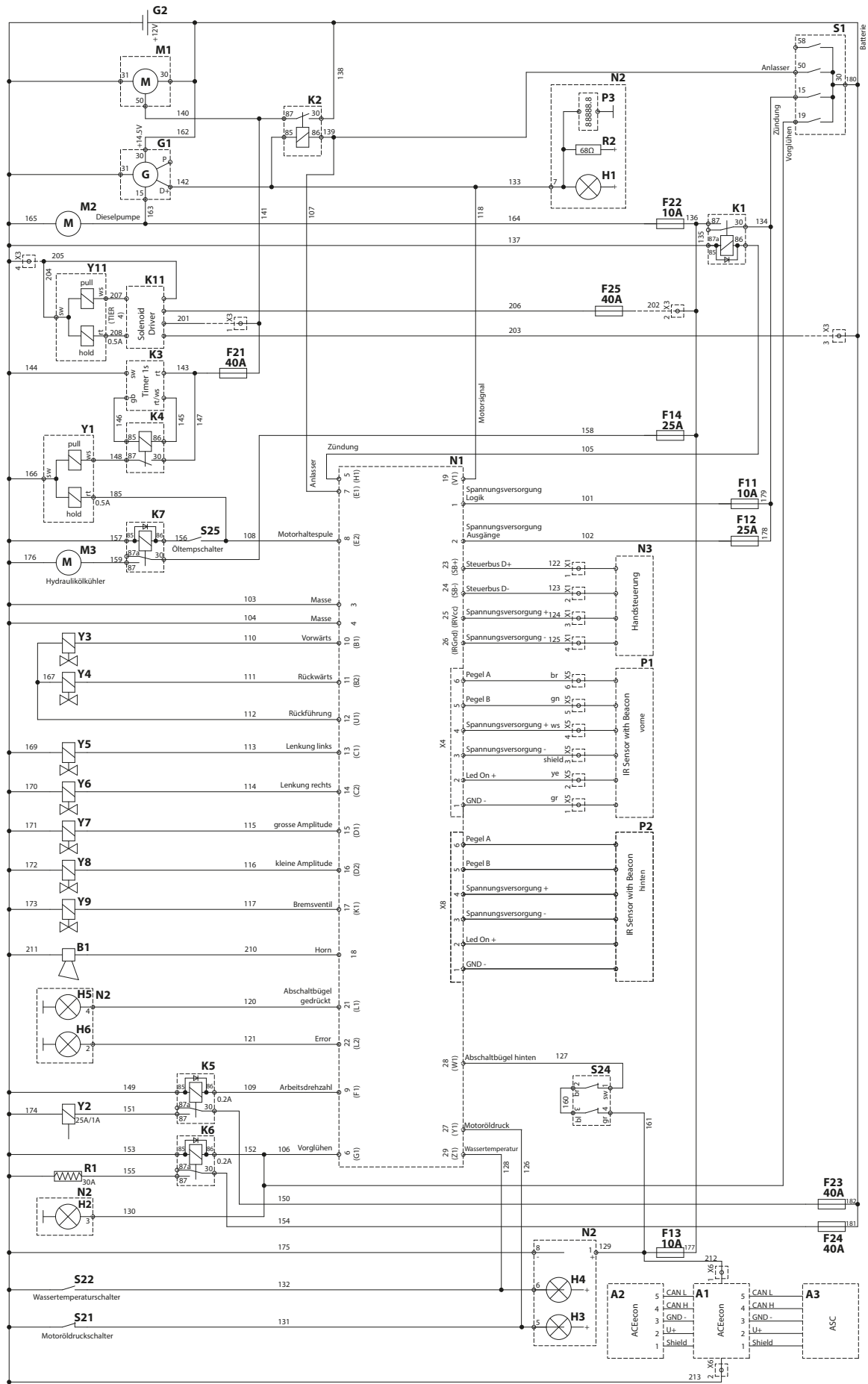

10958087

3.8. Annexes

3.8.2. Hydraulic system diagram

Legend:

- 1 Drive pump
- 2 Vibro-steering pump
- 3 Drive motor, rear left
- 4 Drive motor, rear right
- 5 Front left drive motor
- 6 Front right drive motor
- 7 Left steering cylinder
- 8 Right steering cylinder
- 9 Vibro steering/brake valve
- 10 Vibro motor, front
- 11 Vibro motor, rear
- 12 Oil cooler
- 13 Return-line suction filter
- 14 Hydraulic oil tank
- 15 Filler, ventilation filter
- 16 Diesel tank
- 17 Nozzle block
- 18 Flow divider

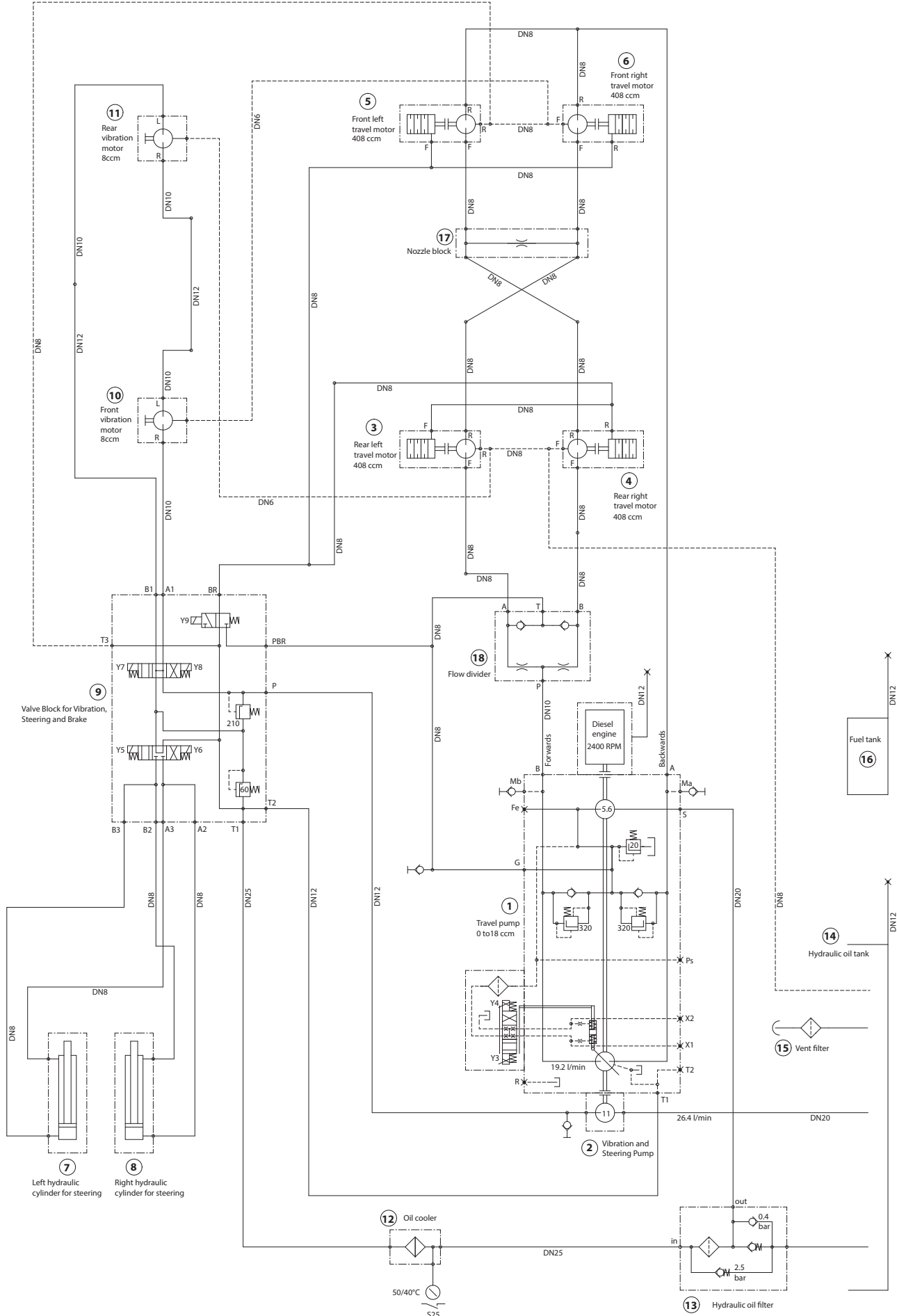

10442344A

3.8. Annexes

3.8.3. Table of spare parts

Chapter	Spare part	Order No.
Every 10 hours of operation (daily)		
3.6.6.	Dust valve	1227914
Every 250 operating hours (3 months)		
3.6.14.	Fan	1-952338
3.6.14.	Belt	1183743
Every 500 hours of operation (6 months)		
3.6.15.	Engine oil filter	1-954075
3.6.16.	Fuel filter element	1-954197
3.6.16.	O-ring	76-10210355520
3.6.16.	Fuel filter element	1-954195
3.6.17.	Filter element	1300309
3.6.17.	Fuel filter element	1300308
Every 1000 operating hours (1 year)		
3.6.18.	Set of hydraulic oil filters	1182946
3.6.18.	Breather filter	1242184
3.6.24.	Drum rubber-metal	1217092
Maintenance - As Needed		
3.6.25.	Gas springs (2 pcs)	1205428

Content of the set of filters after 500 operating hours (4-760099)

Chapter	Spare part	Number of parts	Order No.
3.6.15.	Engine oil filter	1	1-954075
3.6.16.	Fuel filter element	1	1-954195
3.6.16.	O-ring	2	76-10210355520
3.6.16.	Fuel filter element	1	1-954197
3.6.17.	Air filter element	1	1300308
3.6.17.	Filter element	1	1300309
3.6.18.	Set of hydraulic oil filters	1	1182946

Ammann Unternehmungen
Eisenbahnstrasse 25
CH-4901 Langenthal
Phone +41 62 916 61 61

www.ammann-group.com